



Euro NCAP
For Safer Cars

Version 1.2
May 2026

Filming and Photography

Requirements

Crash Protection

Technical Bulletin CP 003

Implementation 1st January 2026

PREFACE

During the test preparation, vehicle manufacturers are encouraged to liaise with the laboratory and to check that they are satisfied with the way cars are set up for testing. Where a manufacturer feels that a particular item should be altered, they should ask the laboratory staff to make any necessary changes. Manufacturers are forbidden from making changes to any parameter that will influence the test, such as dummy positioning, vehicle setting, laboratory environment etc.

It is the responsibility of the test laboratory to ensure that any requested changes satisfy the requirements of Euro NCAP. Where a disagreement exists between the laboratory and manufacturer, the Euro NCAP secretariat should be informed immediately to pass final judgment. Where the laboratory staff suspect that a manufacturer has interfered with any of the set up, the manufacturer's representative should be warned that they are not allowed to do so themselves. They should also be informed that if another incident occurs, they will be asked to leave the test site.

Where there is a recurrence of the problem, the manufacturer's representative will be told to leave the test site and the Secretary General should be immediately informed. Any such incident may be reported by the Secretary General to the manufacturer and the person concerned may not be allowed to attend further Euro NCAP tests.

DISCLAIMER: Euro NCAP has taken all reasonable care to ensure that the information published in this protocol is accurate and reflects the technical decisions taken by the organisation. In the unlikely event that this protocol contains a typographical error or any other inaccuracy, Euro NCAP reserves the right to make corrections and determine the assessment and subsequent result of the affected requirement(s).

CONTENTS

1	INTRODUCTION	4
2	GENERAL FILM AND PHOTOGRAPHY REQUIREMENTS	5
2.1	Digital Data Format, Encoding and Sampling Requirements	5
2.2	Vehicle Markings	7
2.3	Camera Locations	9
2.4	Still Photographs	9
3	FRONTAL MPDB IMPACT	11
3.1	Camera Locations and Views	11
3.2	Still Photographs	15
4	FRONTAL FWDB IMPACT	17
4.1	Vehicle Markings	17
4.2	Camera Locations and Views	17
4.3	Still Photographs	22
5	SIDE MOBILE DEFORMABLE BARRIER IMPACT	24
5.1	Vehicle and Barrier Markings	24
5.2	Camera Locations and Views	24
5.3	Still Photographs	27
6	SIDE OBLIQUE POLE IMPACT	30
6.1	Vehicle and Pole Markings	30
6.2	Camera Locations and Views	30
6.3	Still Photographs	33
7	SLED TESTS	35
7.1	Far Side	35
7.2	Frontal Impact	39
8	VIRTUAL TESTING	43
8.1	Far Side	43
8.2	Frontal Impact	45
9	REAR IMPACT WHIPLASH TESTS	49
9.1	Sled, Seat and Dummy Markings	49
9.2	Camera Locations and Views	50

9.3 Still Photographs	52
10 VULNERABLE ROAD USER SUBSYSTEM TESTS	53
10.1 Vehicle and Other Markings	53
10.2 Camera Locations and Views	53
10.3 Still Photographs	55

1 INTRODUCTION

Euro NCAP test protocols have always included requirements for high speed filming and still photography. High quality visuals are important to accurately record the kinematics of the impact during the test and to support the vehicle inspection and the analysis of the vehicle performance. Increasingly, however, high resolution media are needed for communication purposes such as publications on internet, social media, TV broadcasting, brochures, etc.

Euro NCAP involves several laboratories that each may have their own internal procedures, quality standards and equipment. In order to improve the consistency of material supplied by the laboratories, all film and photo requirements previously specified by Euro NCAP have been brought together, reviewed and updated. This document summarises the most recent specifications that are compulsory for all official Euro NCAP tests at the accredited Euro NCAP test laboratories.

2 GENERAL FILM AND PHOTOGRAPHY REQUIREMENTS

2.1 Digital Data Format, Encoding and Sampling Requirements

2.1.1 Full-Scale Crash Test Films - MPDB, FWT, AE-MDB and Pole Tests

All films should be produced in HD format, apart from on-board camera footage. The films should be sampled at a rate of a minimum of 500 frames per second. All files (including the inspection films and crash test data) should be promptly sent to Euro NCAP Secretariat after the tests.

Three sets of films should be supplied:

a) Inspection Films

- Format: MP4 or AVI.
- Codec: H.264, Data/Bit rate: 2 Mbps.
- Resolution: Native camera resolutions.
- Frame rate: 25 fps.
- Must include burnt in timers.
- File size must be reduced before sending to Euro NCAP Secretariat, using FFmpeg free software (<https://www.ffmpeg.org>). Secretariat will supply a batch converter file separately.
- Full scale and rear impact film start and end time -50ms to 300ms.
- VRU film start and end time -50ms to 150ms.

b) Media Films (For Publication)

- Format: Prores422, or Avid DNxHD-145 QuickTime as an alternative.
- Codecs : Apple Prores422 / Avid DNxHD-145 Quicktime*.
- Resolution: Native camera resolutions.
- Frame rate (time base): 25 fps.
- Display mode: Progressive.
- YUV Format: 4:2:2.
- Colour Depth: 10 bit.
- Films should be supplied without “burnt in” timers, laboratory logos or text.

** If a first conversion pass is necessary prior to convert to prores422/DNxHD: Please use a minimum 10-bit codec / format, or 16-bit image sequences to maintain quality.*

c) Real-Time Films (Supplementary Camera, For Publication)

- Same specifications as for media films above. **The time window for recording should be set to record 10 seconds before the start of the car/trolley moving and 10 seconds of recording after the impact.**

2.1.2 VRU Impact and Whiplash Test Films

Two sets of films should be supplied: a) inspection films and b) media films, as specified in Section 2.1.1. For the whiplash media film please only supply one view: publication wide view high severity pulse.

2.1.3 Sled Test Films

High speed film, 1000fps minimum, is required for physical sled tests and the views are detailed in Section 7. The following specification shall be used:

- Format: MP4 or AVI.
- Codec: H.264, Data/Bit rate: 2 Mbps.
- Resolution: Native camera resolutions.
- Frame rate: 1000 fps.
- Must include burnt in timers

2.1.4 Virtual Test Films

Videos of all animated simulations (ATD and HBM) must meet the following requirements and the views detailed in Section 8:

- Output interval of 2 ms or less.
- Format: .mp4 or .avi
- Codec: H.264
- Frame rate: 10 frames per second
- File size: 1-10 MB
- The resolution/frame size shall be maximised within the file size limit.
- The videos must be recorded from $t=0$ to 'simulation time' in accordance with the definition in the Virtual Testing protocol.
- The timestamp must be clearly visible in all videos.

All videos shall be shared as one .zip file (no specific naming of the .zip file required) in the corresponding 'Movie' folder in each of the VT sub-test folder (see CP 005 Section 1.1.6).

2.2 Vehicle Markings

2.2.1 Euro NCAP markings

Euro NCAP markings will be attached to the exterior of the vehicle in a contrasting colour (black or white) to the test vehicle such that it is clearly visible in the high speed films. Only standardised Euro NCAP (transparent) markings are allowed as supplied by the Euro NCAP Secretariat (dimensions 600 x 300 mm).

Markings on a rigid background should be used for VRU testing and placed on barriers, trolleys or walls (for whiplash testing for example). Test logos and numbers on a simple sheet of paper are not acceptable for publication.

VRU and Whiplash Euro NCAP logo and test references should be located in the upper half of the camera view (so as not to interfere with the video overlays which are usually located at the bottom of the screen.) These markings should also be in the background behind the car and not in the foreground.

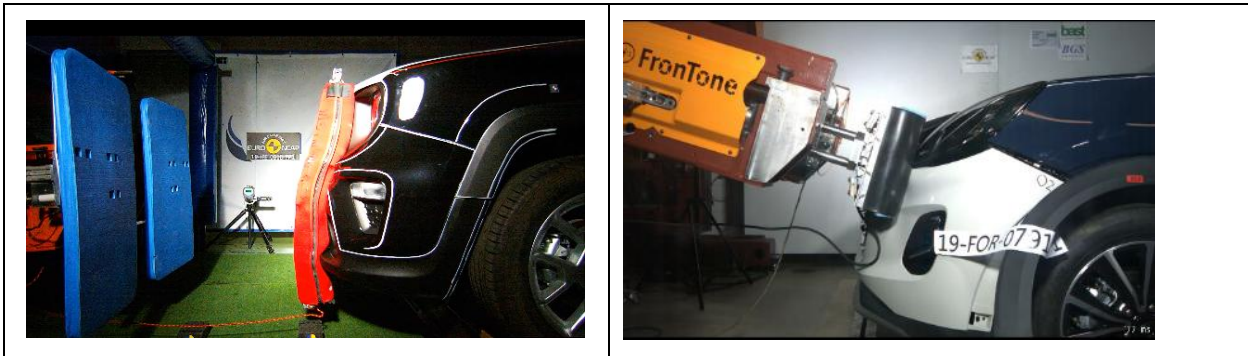

Examples showing correct (left) and incorrect (right) test number location, logo display material, background location.

Euro NCAP markings should be attached to the exterior of the vehicle as shown in Figure 1 below. The unique Euro NCAP test reference number should be placed below each Euro NCAP logo (see Section 2.2.3).

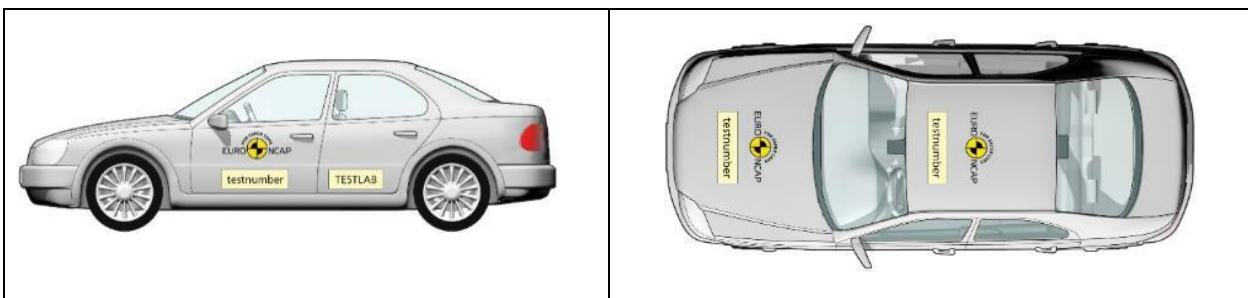

Figure 1: Standardised labels on L/R side, the bonnet and roof area of the test vehicle.

2.2.2 Test house logos

Test house logos may be added to the vehicle on the lower half of the rear doors/rear ¼ panel only for full scale tests and active safety tests. No markings to be placed on the vehicle for VRU sub system tests.

Test house logos should not be placed on the roof area, on the bonnet or anywhere else on the tested vehicle.

The size of test house logos should not exceed that of the Euro NCAP official logo and should not be more prominent in the camera views than the Euro NCAP official logo.

2.2.3 Test numbers

The Euro NCAP Secretariat shall inform the laboratory of the unique Euro NCAP test number prior to the test and this should be used as the main test reference number. This number should also appear on all test data and documents. The test number should be placed in close proximity to each Euro NCAP logo, preferably underneath – if placed underneath leave a space between the logo and the test number.

Reference numbers are provided by Euro NCAP to each laboratory. Please use a vinyl plotter/cutting plotter to produce the test reference number in vinyl of the font type (Etelka Text Pro) and font size (180). Please cut out the numbers so that the full number appears on a single line. The sequence of characters of reference number should always follow the same convention, as shown in this example:

“24-HYU-1234-FW1”,

where “24” is the year of test, “HYU” refers to the car brand, “1234” is Euro NCAP unique key number and “FW1” is the code for the type of (re-)test. Figure 2 below illustrates examples of good and bad reference number size and spacing.

Additional internal test house numbers should be kept as small as possible (never be larger in size than the official reference number) and always be placed below the test house logo (see Section 2.2.2).



Figure 2: Examples showing correct (left) and incorrect (right) font size and reference number spacing and material.

2.3 Camera Locations

In this document, high speed camera layout diagrams are provided for each full scale, sled or track test as a guide to show what part of the vehicle and the surroundings should be in view for each particular camera at T0. Also an example frame from each camera is provided.

When attaching on-board cameras, the vehicle manufacturer should be consulted to ensure that no damage is caused to the vehicle that would influence the impact performance. Additionally, the test laboratory should be informed if the side curtain airbags are expected to deploy during the impact. Where additional equipment is added, the mass shall be compensated when achieving the final test weight. On-board lighting should be used for ALL onboard camera views. The mounting for the camera should ensure that a stable view is obtained throughout the impact without the camera oscillating due to a thin roof panel for example.

No personnel shall be visible in ANY of the high speed camera views. Sufficient lighting shall be provided so as the vehicle and occupants are clearly visible throughout the impact. Also where a camera is recording sound during a test personnel should refrain from talking, as these films are used with audio on the Euro NCAP website.

Back-up cameras are not required and it is up to the test laboratory to decide if they are necessary.

2.4 Still Photographs

Pre-test photographs will be taken with the dummies in their final positions. A list of the required photos pre-, on- and post-test is provided in each relevant test section.

If necessary, tall blank screens should be placed behind the vehicle to get a “clean” photo to avoid other test equipment or personnel appearing in the photos.

No personnel should be visible in ANY of the pre and post-test still photographs.

Stills should have the following specifications:

a) Inspection Stills

- Format: JPEG.
- Resolution: Maximum resolution that the camera allows.
- File size: Compressed (use FFmpeg software as used for compressing the test films in Section 2.1).
- File size must be reduced before sending to Euro NCAP Secretariat, using FFmpeg free software (<https://www.ffmpeg.org>). Secretariat will supply a batch converter file separately.

b) Media Stills (make sure sufficient lighting remains on)

- Format: JPEG.
- Resolution: Maximum resolution that the camera allows.
- File size: No compression or as little compression as possible (Superfine).

- The original still should not be edited.

Photos should be arranged in PRE and POST folders, labs should not separate photos into component folders such as driver, passenger, CRS, vehicle etc.

The inspection quality photos should be supplied with the crash test data (Sharepoint Dataplatform/Lab folder). The media quality photos should be provided to the Secretariat along with the media quality films (Sharepoint Dataplatform/RAWMEDIASFILES).

3 FRONTAL MPDB IMPACT

3.1 Camera Locations and Views

A minimum of 9 cameras should be installed around the test vehicle, positioned as indicated in Figure 3 below. Three (4) additional on-board cameras for child and driver dummy views are to be used. A separate camera (not listed) must record the crash in real time.

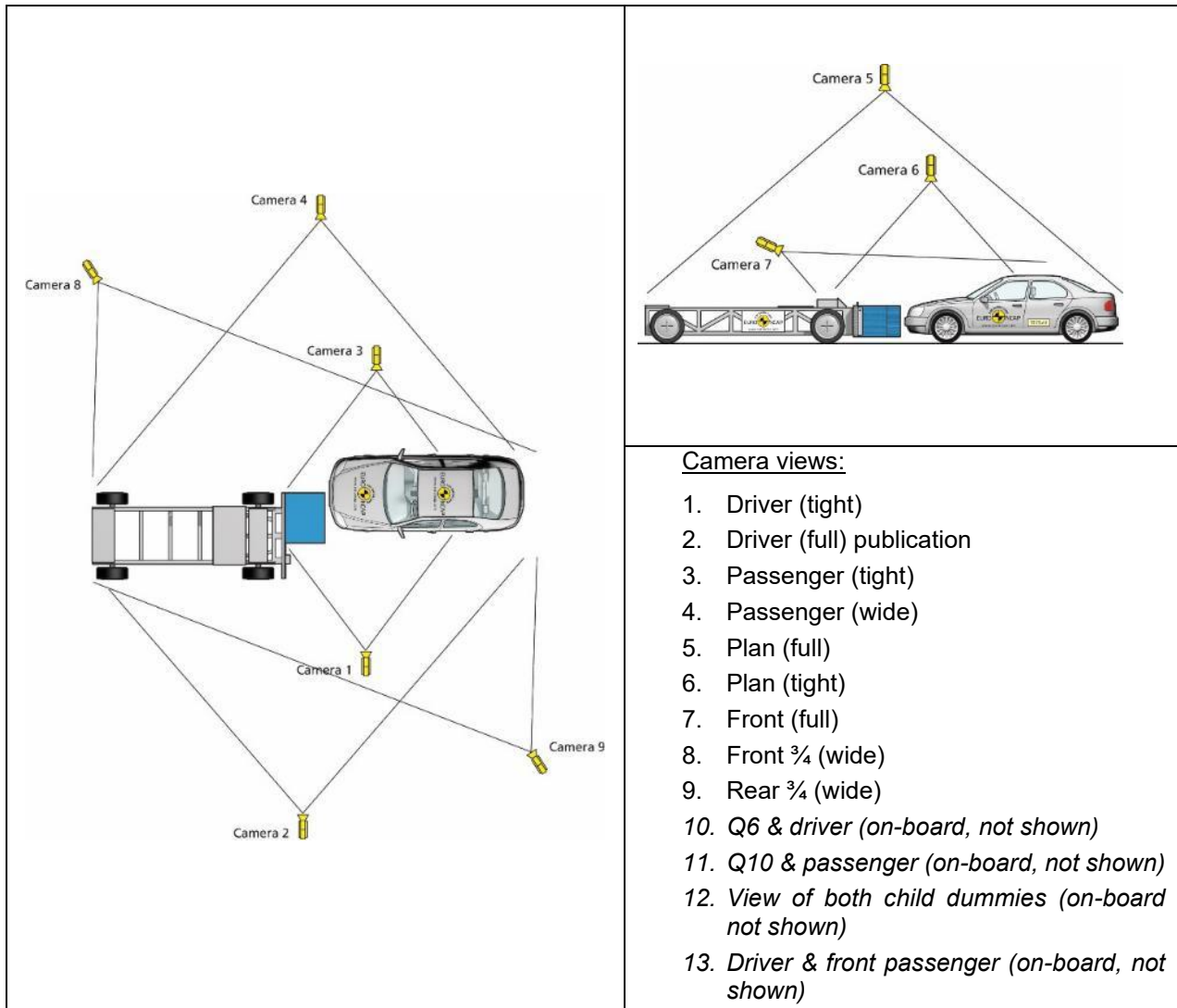









Figure 3: Locations for Cameras 1 to 9 (Frontal MPDB).

Table 1: List of MPDB camera views

	<p>Camera: 1</p>
	<p>Filename: 1_Driver_tight</p>
	<p>Description: The rear of barrier/trolley face to the b-pillar @ T0</p>
	<p>Camera: 2</p>
	<p>Filename: 2_Driver_publication</p>
	<p>Description: (Space allowing) Rear of trolley to rear of vehicle @ T0</p>
	<p>Camera: 3</p>
	<p>Filename: 3_Passenger_tight</p>
	<p>Description: Rear of the B-Pillar to the rear edge of the barrier trolley mount @ T0</p>
	<p>Camera: 4</p>
	<p>Filename: 4_Passenger_wide</p>
	<p>Description: (Space allowing) Entire vehicle and trolley @ T0</p>
	<p>Camera: 5</p>
	<p>Filename: 5_Plan_full</p>
	<p>Description: Entire vehicle and trolley @ T0 (allowing room for rotation also). Indoors this view may not be fully achievable and fish eye lens not desirable.</p>

	<p>Camera: 6</p>
	<p>Filename: 6_Plan_tight</p>
	<p>Description: From b-pillar to the rear edge of trolley front tyres @ T0</p>
	<p>Camera: 7</p>
	<p>Filename: 7_Front_full</p>
	<p>Description: Camera on tripod or suspended from facility roof, not on trolley. Entire vehicle front to rear edge of the barrier @ T0</p>
	<p>Camera: 8</p>
	<p>Filename: 8_Front_Passenger_angled</p>
	<p>Description: Camera centred on impact point, ¾ angle from front passenger side.</p>
	<p>Camera: 9</p>
	<p>Filename: 9_Rear_Driver_angled</p>
	<p>Description: Camera centred on impact point, ¾ angle from rear on driver side.</p>

MPDB onboard cameras:

	<p>Camera</p> <p>10 (on-board)</p>
<p>Filename:</p> <p>10_Q6_onboard</p>	<p>Description:</p> <p>Camera centred on 550mm head excursion line to include steering wheel. Driver's pelvis and femur must be visible.</p> <p>On-board lighting should be used.</p>
	<p>Camera:</p> <p>11 (on-board)</p>
<p>Filename:</p> <p>11_Q10_onboard</p>	<p>Description:</p> <p>Camera centred on 450mm head excursion line. Passenger's pelvis and femur must be visible.</p> <p>On-board lighting should be used.</p>
	<p>Camera:</p> <p>12 (on-board)</p>
<p>Filename:</p> <p>12_both_Q_dummies</p>	<p>Description:</p> <p>Front view of both Q dummies</p>
	<p>Camera</p> <p>13 (on-board)</p>
<p>Filename:</p> <p>13_driver_passenger_onboard</p>	<p>Description:</p> <p>Camera located rearward of front seats, view capturing both front occupants.</p>

3.2 Still Photographs

Table 2: List of photos (Frontal MPDB).

No.	Pre	Post	Media	View
1	•	•		Front view of barrier and trolley.
2	•	•		Side view of barrier and trolley.
3	•	•		Side view of barrier and trolley at 45 degrees to front.
4		•	•	Wide view of car and barrier/trolley from LHS, showing crash lighting (for publication).
5	•	•	•	Car LHS, with camera centred on junction of B-post waist, showing full car (for publication).
6	•	•	•	Car LHS, with camera centred on B-post waist, showing rear passenger compartment (for publication).
7	•	•	•	Car LHS, with camera aimed at waist height, showing driver's compartment (for publication).
8	•	•	•	Car LHS at 45 degrees to front (for publication).
9	•	•	•	Front view of car (for publication).
10	•	•	•	Car RHS at 45 degrees to front (for publication).
11	•	•	•	Car RHS, with camera aimed at waist height, showing front passenger's compartment (for publication).
12	•	•	•	Car RHS, with camera centred on B-post waist, showing rear passenger compartment (for publication).
13	•	•	•	Car RHS, with camera centred on B-post waist, showing full car (for publication).
14	•	•		Driver and seat to show driver compartment and position of seat relative to the sill.
15	•	•		To show area immediately in front of driver.
16	•	•		To show driver's footwell area and location of dummy's feet and pedals.
17	•	•		Passenger and seat to show compartment and position of seat relative to sill.
18	•	•		To show area immediately in front of passenger.
19	•	•		To show passenger footwell area and dummy's feet.
20	•	•		To show both child dummies and restraints through LHS rear door.
21	•	•		To show both child dummies and restraints through RHS rear door
22		•		Overall view of where the car has come to rest after impact (including barrier and trolley).
23		•		To show position of all door latches and/or open doors.
24		•		To show driver knee contacts with facia (airbag should be lifted if obscuring view)
25		•		To show passenger knee contacts with facia (airbag should be lifted if obscuring view).
26	•			LHS rear seat belt anchorage with child restraint and dummy in place.

No.	Pre	Post	Media	View
27	•			RHS rear seat belt anchorage with child restraint and dummy in place.
28		•		Q6 dummy and restraint through RHS rear door.
		•		Q10 dummy and restraint through LHS rear door.

After Dummy Removal:

No.	Pre	Post	View
31		•	Passenger compartment from rear window.
32		•	RHS interior from LHS of car.
33		•	LHS interior from RHS of car.
34		•	RHS front door area.
35		•	LHS front door area.
36		•	Facia.
37		•	Passenger footwell.
38		•	Driver footwell.
39		•	Steering wheel taken perpendicular to driver's side.
40		•	Driver right knee impact point.
41		•	Driver left knee impact point.
42		•	Passenger knee impact area.

Screen Captures / On Test Stills:

In addition to the pre- and post-test stills, a set of pictures captured during the crash (driver's view full) need to be provided, as follows: (1) the car deep into the barrier, (2) the airbag in deployment, (3) airbag fully deployed and (4) head of the dummy reaching the full extent of forward motion.

The list of photos is intended to be used as a guide and if the laboratory photographer finds some other interesting or unusual test occurrences these should also be photographed.

4 FRONTAL FWDB IMPACT

4.1 Vehicle Markings

Euro NCAP markings should be attached to the exterior of the vehicle as shown in Figure 1, Section 2.2.1. The unique Euro NCAP test reference number should be placed below each Euro NCAP logo (see Section 2.2.3).

4.2 Camera Locations and Views

A total of 7 cameras views are required as indicated in Figure 4 below. In addition, two (2) onboard camera views are specified, for driver and rear passenger respectively and one real-time camera located on the block.

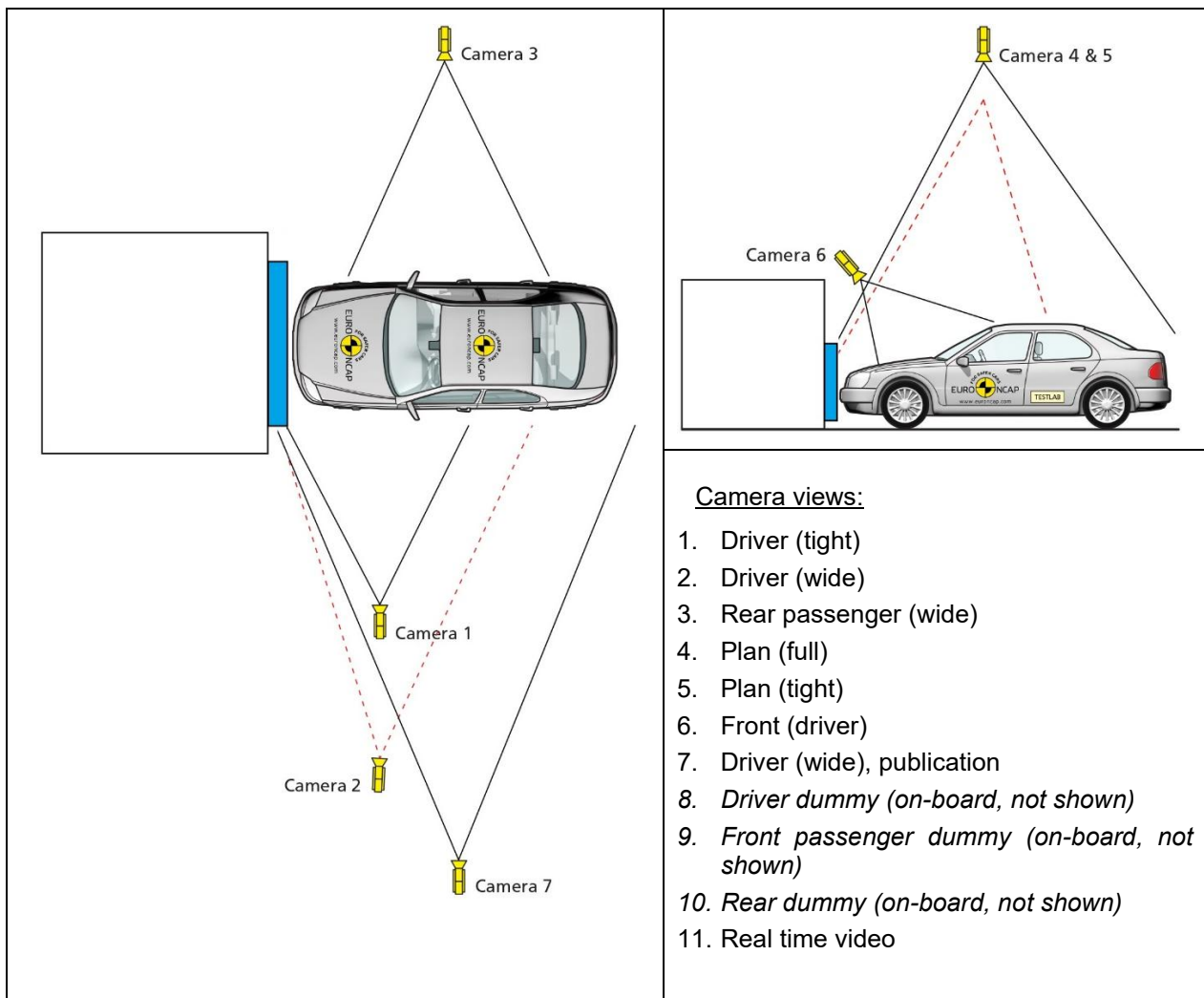



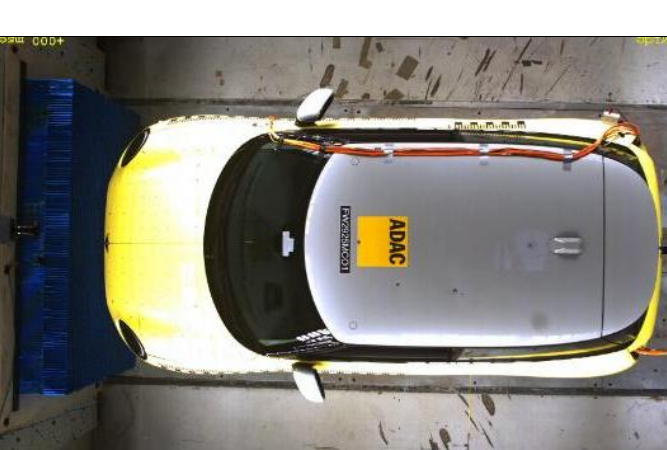
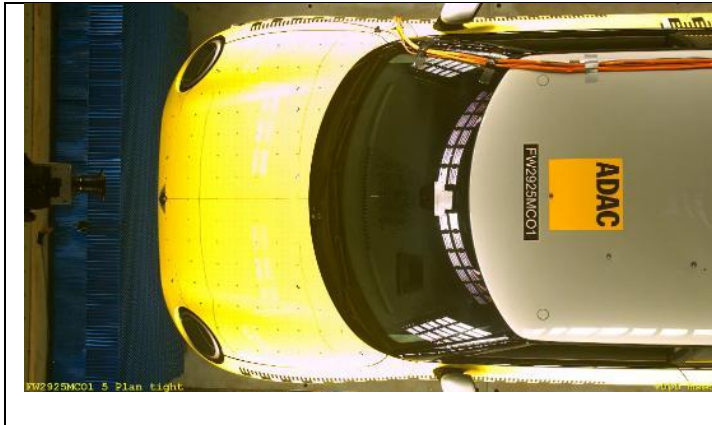

Figure 4: Locations for Cameras 1 to 7 (Frontal Full Width Rigid Barrier).

Table 3: List of camera views (Frontal Full Width Rigid Barrier).

	<table border="1"> <tr> <td>Camera:</td> <td>1</td> </tr> <tr> <td>Filename:</td> <td>1_Driver_tight</td> </tr> <tr> <td>Description:</td> <td>The rear of driver dummy head to block @ T0</td> </tr> </table>	Camera:	1	Filename:	1_Driver_tight	Description:	The rear of driver dummy head to block @ T0
Camera:	1						
Filename:	1_Driver_tight						
Description:	The rear of driver dummy head to block @ T0						
	<table border="1"> <tr> <td>Camera:</td> <td>2</td> </tr> <tr> <td>Filename:</td> <td>2_Driver_wide</td> </tr> <tr> <td>Description:</td> <td>Front and rear occupants in view @ T0</td> </tr> </table>	Camera:	2	Filename:	2_Driver_wide	Description:	Front and rear occupants in view @ T0
Camera:	2						
Filename:	2_Driver_wide						
Description:	Front and rear occupants in view @ T0						
	<table border="1"> <tr> <td>Camera:</td> <td>3</td> </tr> <tr> <td>Filename:</td> <td>3_Rear_passenger_wide</td> </tr> <tr> <td>Description:</td> <td>Just rear of the passenger head to centre of front wheel</td> </tr> </table>	Camera:	3	Filename:	3_Rear_passenger_wide	Description:	Just rear of the passenger head to centre of front wheel
Camera:	3						
Filename:	3_Rear_passenger_wide						
Description:	Just rear of the passenger head to centre of front wheel						
	<table border="1"> <tr> <td>Camera:</td> <td>4</td> </tr> <tr> <td>Filename:</td> <td>4_Plan_full</td> </tr> <tr> <td>Description:</td> <td>Rear of the vehicle to the block. The entire vehicle should be in view @ T0</td> </tr> </table>	Camera:	4	Filename:	4_Plan_full	Description:	Rear of the vehicle to the block. The entire vehicle should be in view @ T0
Camera:	4						
Filename:	4_Plan_full						
Description:	Rear of the vehicle to the block. The entire vehicle should be in view @ T0						



Camera:	5
Filename:	5_Plan_tight
Description:	B-pillar to the block

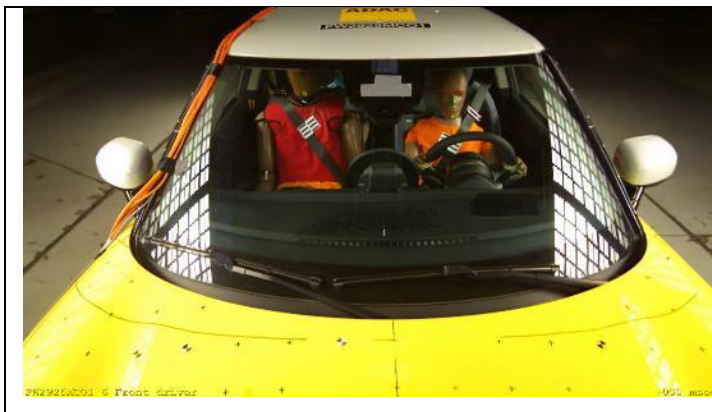

Camera:	6
Filename:	6_Front_driver
Description:	Front edge of the roof to base of windscreen/edge of bonnet



Camera:	7
Filename:	7_Driver_wide_publication
Description:	Rear of vehicle to block. The entire vehicle should be in view @ T0

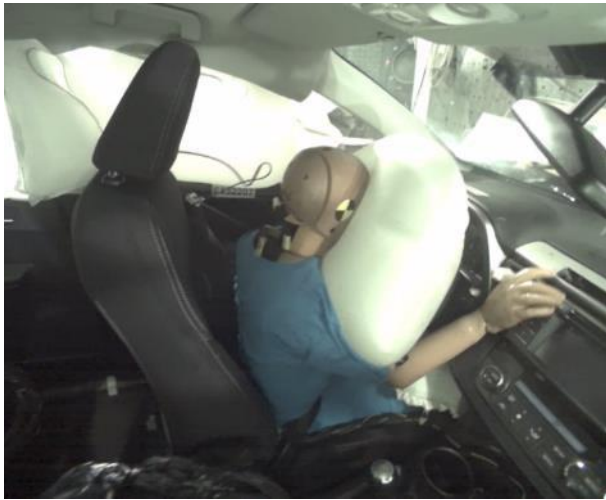



Camera:	8 (on-board)
Filename:	8_Driver_onboard
Description:	<p>Required view @ T0: Camera centred on driver head CoG.</p> <p><u>Driver seat, belt buckle and majority of driver dummy</u> should be in view.</p> <p>Required view @ max forward movement: <u>Driver seat, belt buckle and majority of driver dummy</u> should be in view. Care should be taken to secure or route dummy cables so they do not obscure view of dummy during impact.</p>

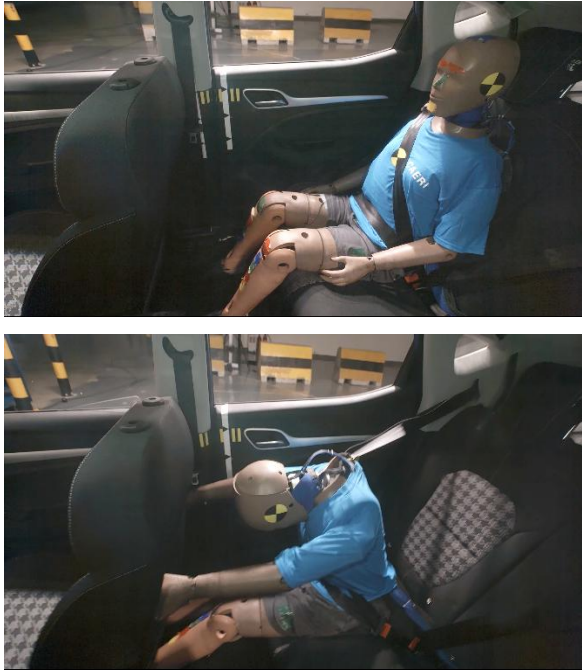

Camera:	9 (on-board)
Filename:	9_Front_passenger_onboard
Description:	<p>Camera centred on head CoG.</p> <p><u>Passenger seat, belt buckle and majority of dummy</u> should be in view.</p> <p>Required view @ T0: Camera centred on excursion line with <u>dummy head, both femurs and belt buckle</u> in view.</p>

	<p>Required view @ max head excursion: <u>Passenger seat, belt buckle and majority of dummy should be in view.</u> Care should be taken to secure or route dummy cables so they do not obscure view of dummy during impact.</p>
---	---

	<table border="1"> <tr> <td>Camera:</td> <td>10 (on-board)</td> </tr> <tr> <td>Filename:</td> <td>10_Rear_dummy_onboard</td> </tr> <tr> <td>Description:</td> <td> <p>Excursion lines must be visible vertically down to the bottom of the door.</p> <p>Required view @ T0: Camera should be centred on excursion line with <u>dummy head, both femurs and belt buckle</u> in view.</p> <p>Required view @ max head excursion: <u>dummy head & arms</u></p> </td> </tr> </table>	Camera:	10 (on-board)	Filename:	10_Rear_dummy_onboard	Description:	<p>Excursion lines must be visible vertically down to the bottom of the door.</p> <p>Required view @ T0: Camera should be centred on excursion line with <u>dummy head, both femurs and belt buckle</u> in view.</p> <p>Required view @ max head excursion: <u>dummy head & arms</u></p>
Camera:	10 (on-board)						
Filename:	10_Rear_dummy_onboard						
Description:	<p>Excursion lines must be visible vertically down to the bottom of the door.</p> <p>Required view @ T0: Camera should be centred on excursion line with <u>dummy head, both femurs and belt buckle</u> in view.</p> <p>Required view @ max head excursion: <u>dummy head & arms</u></p>						

	<table border="1"> <tr> <td>Camera:</td> <td>11</td> </tr> <tr> <td>Filename:</td> <td>11_Realttime_publication</td> </tr> <tr> <td>Description:</td> <td> <p>Camera mounted on block. Check for unwanted objects or persons in view, record sound.</p> </td> </tr> </table>	Camera:	11	Filename:	11_Realttime_publication	Description:	<p>Camera mounted on block. Check for unwanted objects or persons in view, record sound.</p>
Camera:	11						
Filename:	11_Realttime_publication						
Description:	<p>Camera mounted on block. Check for unwanted objects or persons in view, record sound.</p>						

4.3 Still Photographs

Table 4: List of photos (Frontal Full Width Rigid Barrier).

No.	Pre	Post	Media	View
1	•	•		Front view of block.
2	•	•		Side view of block.
3	•	•		Side view of block at 45 degrees to front.
4	•	•	•	Side view of block with vehicle (for publication).
5		•	•	Wide view of car and block LHS, showing crash lighting (for publication).
6	•	•	•	Car LHS, with camera centred on junction of B-post waist, showing full car (for publication).
7		•		Car LHS, with camera centred on B-post waist, showing rear passenger compartment.
8	•	•	•	Car LHS, with camera aimed at waist height, showing driver's compartment (for publication).
9	•	•	•	Car LHS at 45 degrees to front (for publication).
10	•	•	•	Front view of car (for publication).
11	•	•	•	Car RHS at 45 degrees to front (for publication).
12	•	•	•	Car RHS, with camera aimed at waist height, showing front passenger's compartment (for publication).
13	•	•	•	Car RHS, with camera centred on B-post waist, showing rear passenger compartment (for publication).
14	•	•	•	Car RHS, with camera centred on B-post waist, showing full car (for publication).
15	•	•		Driver and seat to show driver compartment and position of seat relative to the sill.
16	•	•		To show area immediately in front of driver.
17	•	•		To show driver's foot well area and location of dummy's feet and pedals.
18	•	•		Rear passenger and seat to show compartment.
19	•	•		To show passenger foot well area and dummy's feet.
20	•	•		To show rear passenger through LHS rear door.
21	•	•		To show rear passenger through RHS rear door.
22		•		Overall view of where the car has come to rest after impact (including block).
23		•		To show position of all door latches and/or open doors.
24		•		To show driver knee contacts with facia (airbag should be lifted if obscuring view).

After Dummy Removal:

No.	Pre	Post	View
25		•	Passenger compartment from rear window.
26		•	RHS interior from LHS of car.
27		•	LHS interior from RHS of car.
28		•	RHS front door area.
29		•	LHS front door area.
30		•	Facia.
31		•	Steering wheel taken perpendicular to driver's side.
32		•	Driver right knee impact point.
33		•	Driver left knee impact point.
34		•	Rear Passenger knee impact area on rear of front seat.

Note: The above requirements are for a LHD car, for a RHD car camera locations will switch sides.

Screen Captures / On Test Stills:

In addition to the pre- and post-test stills, a set of pictures captured during the crash (driver's view full) need to be provided, as follows: (1) the car well into the barrier, (2) the airbag in deployment, (3) airbag fully deployed and (4) head of the dummy reaching the full extent of forward motion. The list of photos is intended to be used as a guide and if the laboratory photographer finds some other interesting or unusual test occurrences these should also be photographed.

5 SIDE MOBILE DEFORMABLE BARRIER IMPACT

5.1 Vehicle and Barrier Markings

Euro NCAP markings should be attached to the exterior of the vehicle as shown in Figure 1, Section 2.2.1. The unique Euro NCAP test reference number should be placed below each Euro NCAP logo (see Section 2.2.3). Euro NCAP markings should also be stuck to the front of the trolley on both sides. Test house logos may be added to the trolley provided that they do not detract attention from the Euro NCAP markings.

5.2 Camera Locations and Views

A minimum of 5 cameras should be installed around the test vehicle, positioned as indicated in Figure 5 below. Two (2) additional on-board cameras to assess child dummy head containment are to be used and also one real time camera. Where required there will be two additional onboard cameras for the driver and passenger front and rear views.

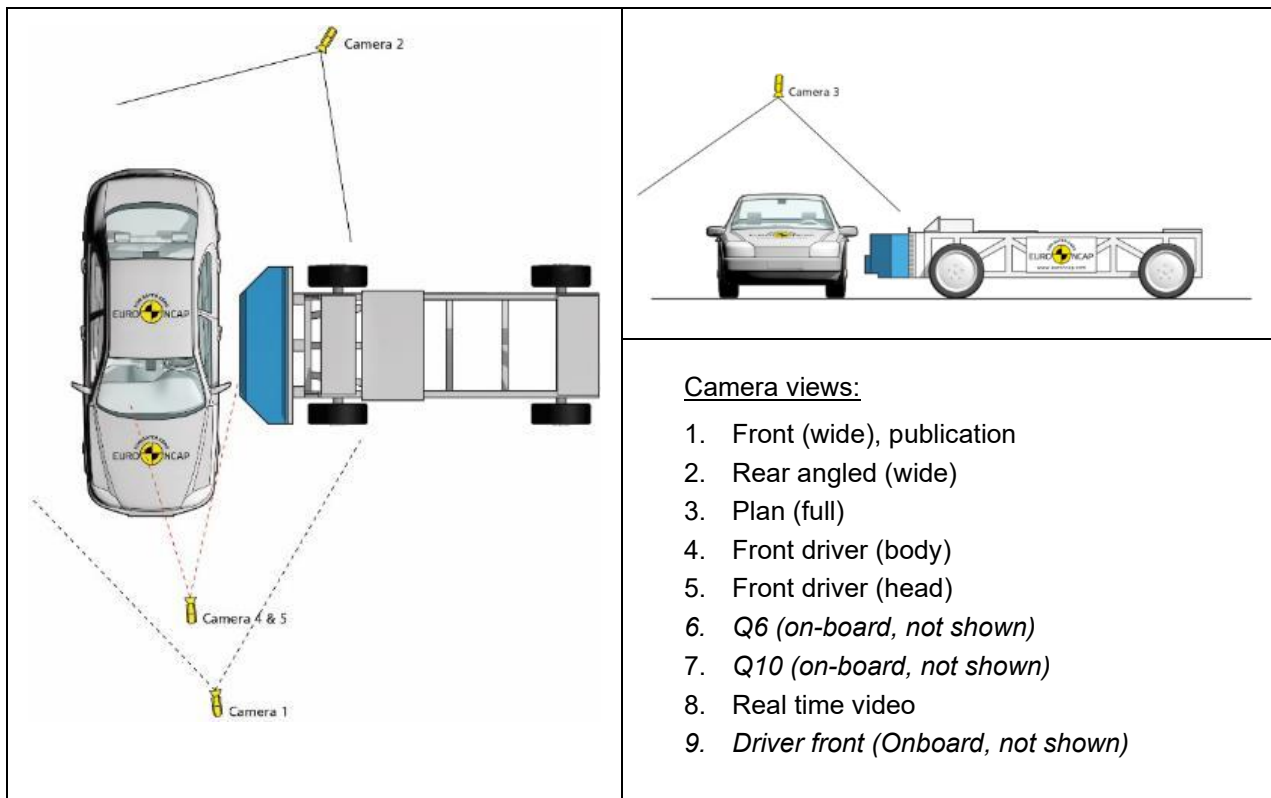











Figure 5: Locations for Cameras 1 to 5 (Side Moving Deformable Barrier).

Table 5: List of camera views (Side Moving Deformable Barrier).

	Camera:	1
	Filename:	1_Front_wide_publication
	Description:	Trolley logo to 1 car width beyond non-struck side of vehicle @ T0
	Camera:	2
	Filename:	2_Rear_angle_wide
	Description:	Angled view to catch any door opening on struck side
	Camera:	3
	Filename:	3_Plan_full
	Description:	Front of trolley to one car width beyond non-struck side of vehicle. The entire vehicle should be in view @ T0.
	Camera:	4
	Filename:	4_driver_body
	Description:	Edge of driver's door to at least the outboard edge of front passenger seat. The driver's thorax and abdomen should be visible @ T0

	Camera:	5
	Filename:	5_driver_head
	Description:	<p>Edge of driver's door to at least the outboard edge of front passenger seat.</p> <p>The driver's head should be visible @ T0</p>
	Camera:	6 (on-board) Q6
	Filename:	6_Q6_onboard
	Description:	<p>Required view @ T0:</p> <p>Positioned between Q6 CRS & vehicle centreline.</p> <p>Passenger head restraint may be removed if possible. The wings of CRS should be visible, possibly by marking with white tape.</p>
	Camera:	7 (on-board) Q10
	Filename:	7_Q10_onboard
	Description:	<p>Required view @ T0:</p> <p>Positioned on Q6 excursion line, slightly rotated towards Q10 centreline.</p> <p>Avoid head restraints and centre airbags.</p>

	Camera:	8
	Filename:	8_Rear_angle_realtime
	Description:	Angled view to catch any door opening on struck side.
	Camera:	9
	Filename:	9_Driver_Front
	Description:	Driver, both B-pillars and front door panels visible

5.3 Still Photographs

Table 6: List of photos (Side Moving Deformable Barrier).

No.	Pre	Post	Media	View
1	•	•		Front view of barrier.
2	•	•		Side view of barrier.

No.	Pre	Post	Media	View
3	•	•		Side view of barrier at 45 degrees to front.
4	•	•	•	Side view of barrier with vehicle, from front of vehicle (for publication).
5		•	•	Side view of barrier with vehicle, from rear of vehicle (for publication).
6		•	•	Wide view of entire trolley and entire vehicle showing struck side, from front of vehicle (for publication).
7		•	•	Wide view of entire trolley and entire vehicle showing struck side, from rear of vehicle (for publication).
8	•	•	•	Car LHS, with camera centred on B-post waist, showing full car (for publication).
9	•	•		Car LHS, with camera centred on B-post waist, showing the rear passenger compartment.
10	•	•		Car LHS, with camera aimed at waist height, showing driver's compartment.
11	•	•	•	Car LHS at 45 degrees to rear (for publication).
12	•	•	•	Car LHS at 45 degrees to front (for publication).
13	•	•	•	Front view of car (for publication).
14	•	•	•	Car RHS, with camera centred on B-post waist, showing full car (for publication).
15	•	•		Car RHS, with camera centred on B-post waist, showing the rear passenger compartment.
16		•		To show position of all door latches and/or open doors.
17	•	•		Driver & seat through open driver's door to show driver compartment and position of seat relative to the sill.
18	•	•		To show area immediately in front of driver.
19	•	•		To show child dummies and restraints through LHS rear door.
20	•	•		To show child dummies and restraints through RHS rear door.
21		•		Car and barrier at rest at 45 degrees to front of car.
22		•		Car and barrier at rest at 45 degrees to rear of car.

After Dummy Removal:

No.	Pre	Post	View
23		•	View through RHS front passenger door of driver's door interior panel & paint marks from dummy ribs.

Note: The above photos are for a LHD car, for a RHD car camera locations will switch sides.

Screen Captures / On Test Stills:

In addition to the pre- and post-test stills, a set of pictures captured during the crash (front wide view) need to be provided, as follows: (1) barrier well into the car, (2) the airbag in deployment, (3) airbag fully deployed and (4) dummy's head in airbag.

The list of photos is intended to be used as a guide and if the laboratory photographer finds some other interesting or unusual test occurrences these should also be photographed.

6 SIDE OBLIQUE POLE IMPACT

6.1 Vehicle and Pole Markings

Euro NCAP markings should be attached to the exterior of the vehicle as shown in Figure 1, Section 2.2.1. The unique Euro NCAP test reference number should be placed below each Euro NCAP logo (see Section 2.2.3). No markings, targets excluded, are allowed on the pole itself. This includes test house logos.

6.2 Camera Locations and Views

A minimum of 6 cameras should be installed around the test vehicle, positioned as indicated in Figure 6 below. No on-board cameras are required.

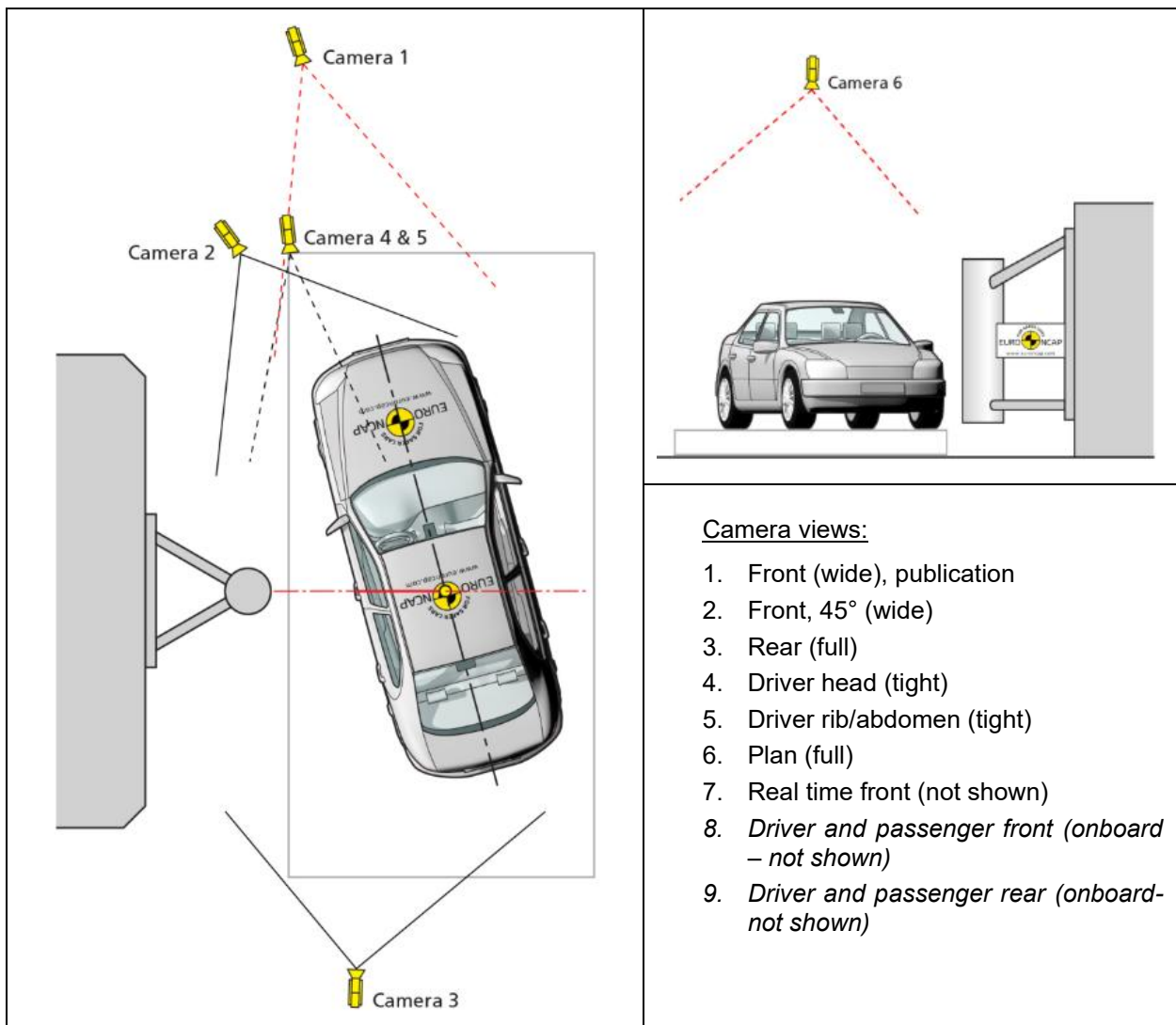

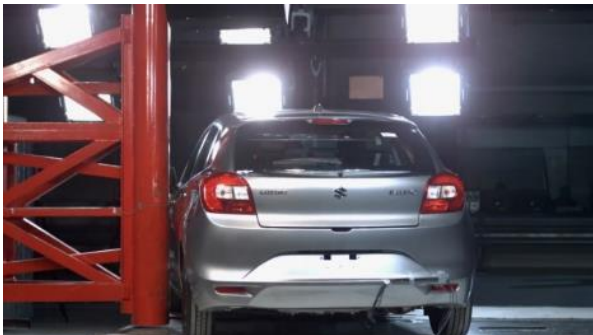







Figure 6: Locations for Cameras 1 to 6 (Side Oblique Pole).

Table 7: List of camera views (Side Oblique Pole).

	Camera:	1
	Filename:	1_Front_wide_publication
	Description:	Camera aligned with vehicle centreline @ T0. Rear of pole to 1m beyond non-struck side of vehicle
	Camera:	2
	Filename:	2_Front_45_wide
	Description:	Camera positioned at 45° to vehicle centreline @ T0. Rear of pole to 1m beyond non-struck side of vehicle
	Camera:	3
	Filename:	3_Rear_full
	Description:	Rearward of pole to 1m beyond non-struck side of vehicle. The entire vehicle should be in view @ T0 and the camera should be positioned to be perpendicular to direction of moving floor.
	Camera:	4
	Filename:	4_Driver_head_tight
	Description:	Pole to the passenger side of the vehicle @ T0. Camera should be positioned to be perpendicular to direction of moving floor.

	Camera:	5
	Filename:	5_Driver_body
	Description:	Passenger side of vehicle to the pole. The driver's thorax and abdomen should be visible @ T0
	Camera:	6
	Filename:	6_Plan_full
	Description:	Entire vehicle should be in view @ T0
	Camera:	7
	Filename:	7_Front_realtime
	Description:	Real time view using same view as high speed camera view 2.
	Camera:	8
	Filename:	8_DriverPass_Front
	Description:	Both occupants (where fitted), both B-pillars and front door panels visible

	Camera:	9
	Filename:	9_DriverPass_Rear
	Description:	Both occupants (where fitted), both B-pillars and rear panels visible

6.3 Still Photographs

Table 8: List of photos (Side Oblique Pole).

No.	Pre	Post	Media	View
Car on carrier against pole:				
1	•	•	•	Top view of full car, carrier and pole (for publication).
2	•	•	•	Front view of full car, carrier and pole (for publication).
3	•	•		Rear view of full car, carrier and pole.
4	•	•	•	Side view of car, carrier and pole at 45 ° to front, impact side (for publication).
5	•	•	•	Side view of car, carrier and pole at 45 ° to rear, impact side (for publication).
6		•	•	Wide view of pole and entire vehicle, from front of vehicle (for publication).
7		•	•	Wide view of pole and entire vehicle, from rear of vehicle (for publication).
Car and carrier away from pole:				
8	•	•	•	Side view car/carrier impact side, showing full car (for publication).
9	•	•		Side view car/carrier non-impact side, showing full car.
10		•		To show position of all door latches and/or open doors.
11	•			Side view through open driver's door on driver & seat to show driver compartment and position of seat relative to the sill.
12	•			Detail view on driver's legs and feet through open door.
13	•	•		Side view through open front passenger door to show driver.
14	•	•		Side view of car/carrier impact side centred on impact line showing front door and B-post.
15	•			Front/side view of pole.
16		•		Front view of dummy through front windscreen.
17	•	•		Inside car view on abdomen/pelvis area.
After dummy removal				
18		•		Detail view(s) on paint marks on the driver's door and seat

Note: The above photos are for a LHD car, for a RHD car camera locations will switch sides.

Screen Captures / On Test Stills:

In addition to the pre- and post-test stills, a set of pictures captured during the crash (front wide or front 45° wide) need to be provided, as follows: (1) showing car well into pole, (2) the airbag in deployment, (3) airbag fully deployed and (4) dummy's head in airbag.

The list of photos is intended to be used as a guide and if the laboratory photographer finds some other interesting or unusual test occurrences these should also be photographed.

7 PHYSICAL SLED TESTS

7.1 Far Side

7.1.1 Body in White Markings

The Euro NCAP test reference ID must be attached physical to the sled and be visible in all camera views.

7.1.2 Camera Locations and Views

A minimum of 5 cameras should be installed around the test vehicle, positioned as indicated below.

Two cameras must be positioned either side of the zone in which the head excursion is anticipated. For example, if the excursion is expected in the orange zone, cameras 2 & 3 will be the minimum required, camera 6 would be placed on the orange line.

Where the camera positions are overlapping, the highest priority regarding camera positioning should be given to camera 1, but camera 2 is still required.

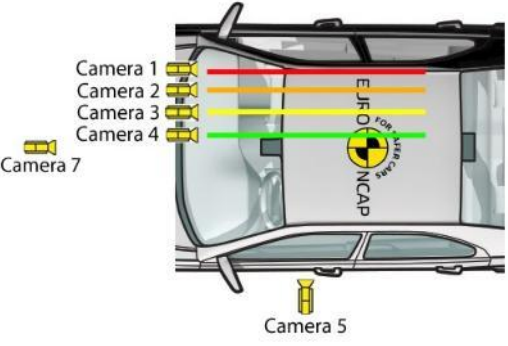
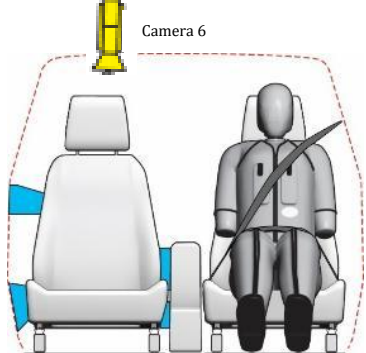
	
<p><u>Onboard camera views:</u></p> <ol style="list-style-type: none">1. Front, red line2. Front, orange line3. Front, yellow line4. Front, green line5. Side, driver pre-test pelvis to head6. Plan, most outboard head excursion line	<p><u>Offboard camera views:</u></p> <ol style="list-style-type: none">7. Front, parallel to vehicle centreline

	Camera:	1
	Filename:	1_Front , red line
	Description:	<p>Front view centred to intrusion limit and parallel to vehicle centreline.</p> <p>Frame width: Outboard edge of A-pillar to far side seat centreline.</p> <p>Frame height: Front edge of roof to seat base.</p>

	Camera:	2
	Filename:	2_Front , orange line
	Description:	<p>Front view centred to seat centreline, parallel to vehicle centreline.</p> <p>Frame width: Outboard edge of A-pillar to far side B-pillar.</p> <p>Frame height: Front edge of roof to seat base.</p>

	Camera:	3
	Filename:	3_Front, yellow line
	Description:	<p>Front view centred to yellow line, parallel to vehicle centreline.</p> <p>Frame width: Outboard edge of A-pillar to far side B-pillar</p> <p>Frame height: Front edge of roof to seat base.</p>

	Camera:	4
	Filename:	4_Front, green line
	Description:	Front view centred to green line, parallel to vehicle centreline. Frame width: Outboard edge of B-pillar to far side B-pillar. Frame height: Front edge of roof to seat base.

	Camera:	5
	Filename:	5_Side, driver
	Description:	Side view of driver centred to middle of door aperture, door waist height. Frame width: Facia to rear of seat back Frame height: Head to pelvis.

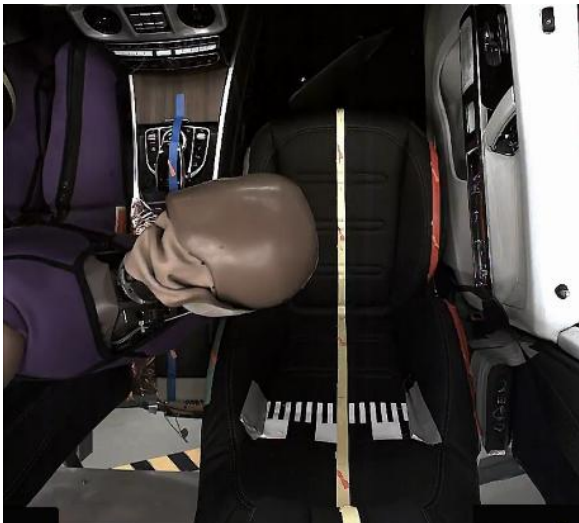
	Camera:	6
	Filename:	6_Plan, max excursion
	Description:	Frame width: Facia to rear of seat back Frame height: Far side seat centreline to B-pillar.

	Camera:	7
	Filename:	7_Front, BIW
	Description:	<p>Front, parallel to vehicle centreline.</p> <p>Frame width: Full width of BIW.</p> <p>Frame height: Full height of BIW.</p>

7.1.3 Still Photographs

No.	Pre	Post	Media	View
1.	•	•		Top view of full BIW
2.	•	•		Front view of full BIW
3.	•	•		Rear view of full BIW
4.	•	•		Side view of full BIW
5.	•			Left and right B-pillar instrumentation
6.	•	•		Driver's side view of BIW at 45 ° to front
7.	•	•		Passenger's side view of BIW at 45 ° to front
8.	•	•		Side view of driver from outside
9.	•	•		Side view of driver from inside (including paint)
10.	•	•		Front view of driver
11.	•	•		Rear view of spacers in position
After dummy removal				
12.		•		Paint transfer to centre console
13.		•		Paint transfer to passenger's side door/airbags (if applicable)

7.2 Frontal Impact

7.2.1 Body in White Markings

The Euro NCAP test reference ID must be attached physical to the sled and be visible in all camera views.

7.2.2 Camera Locations and Views

A minimum of 8 cameras are to be installed and positioned as indicated below.

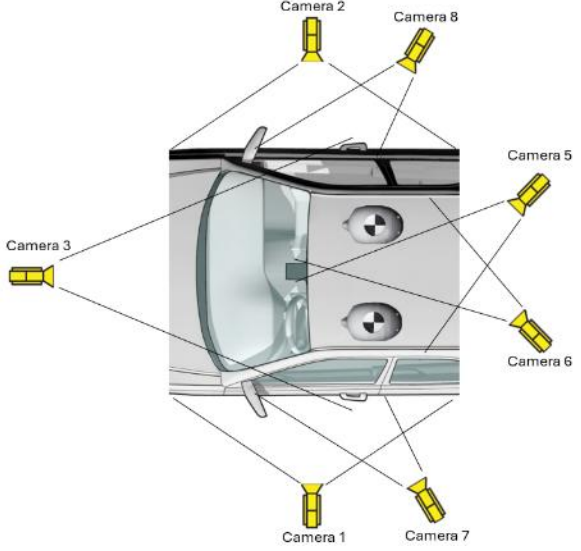
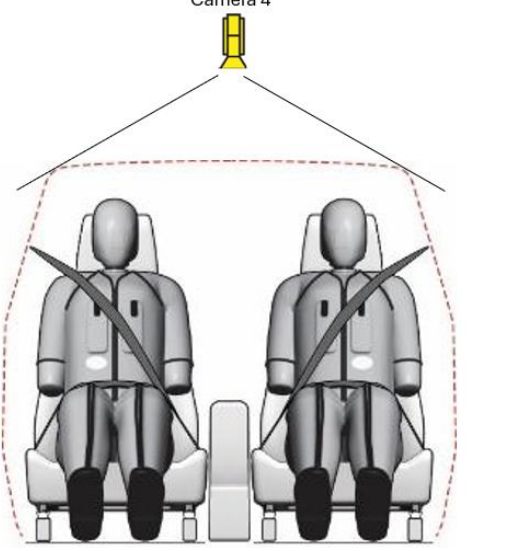
	
<p><u>Onboard camera views:</u></p> <ol style="list-style-type: none"> 1. Side, right 2. Side, left 	<p><u>Offboard camera views:</u></p> <ol style="list-style-type: none"> 3. Front, occupants 4. Plan, row 1 5. Driver, onboard 6. Passenger, onboard 7. <u>Driver, legs & footwell</u> 8. <u>Passenger, legs & footwell</u>

	<p>Camera:</p>	<p>1</p>
	<p>Filename:</p>	<p>1_Side_right</p>
	<p>Description:</p>	<p>Right side view of occupant(s) and BIW. Front of A-pillar to rear of B-pillar.</p> <p>Full duration of impact must be visible.</p>

	Camera:	2
	Filename:	2_Side_left
	Description:	Left side view of occupant(s) and BIW. Front of A-pillar to rear of B-pillar. Full duration of impact must be visible.

	Camera:	3
	Filename:	3_Front_occupants
	Description:	Front view of both occupants. Both seats must be in the frame with roof and scuttle. View must be largely unobscured.

	Camera:	4
	Filename:	4_Plan_row1_onboard
	Description:	Plan view positioned above the occupants. Both seats and facia must be in the frame. View must be largely unobscured.

	Camera:	5
	Filename:	5_Driver_onboard
	Description:	Driver seat and facia. Belt buckle and majority of driver dummy should be in view.

	Camera:	6
	Filename:	6_Passenger_onboard
	Description:	Passenger seat and fascia. Belt buckle and majority of passenger dummy should be in view.

	Camera:	7
	Filename:	7_Driver_footwell_onboard
	Description:	Driver lower fascia and footwell. Adequate lighting must be provided.

	Camera:	8
	Filename:	8_Passenger_footwell_onboard
	Description:	Passenger fascia and footwell. Adequate lighting must be provided.

7.2.3 Still Photographs

No.	Pre	Post	View
1.	•	•	Front view of BIW and sled
2.	•	•	Left and right side view of BIW and sled
3.	•	•	Left and right side view of BIW and sled at 45 degrees to front.
4.	•		Left and right B-pillar instrumentation
5.	•	•	Driver and seat to show BIW and position of seat relative to the sill.
6.	•	•	Area immediately in front of driver.
7.	•	•	Driver's footwell area and location of dummy's feet and pedals.
8.	•	•	Passenger and seat to show compartment and position of seat relative to sill.

No.	Pre	Post	View
9.	•	•	Area immediately in front of passenger.
10.	•	•	Passenger footwell area and dummy's feet.
11.		•	Driver knee contacts with facia or knee airbag (head airbag may be lifted if obscuring view)
12.		•	To show passenger knee contacts with facia or airbag (head airbag may be lifted if obscuring view).

After Dummy Removal:

No.	Pre	Post	View
13.		•	RHS interior from LHS of car.
14.		•	LHS interior from RHS of car.
15.		•	RHS front door area.
16.		•	LHS front door area.
17.		•	Facia.
18.		•	Driver's footwell.
19.		•	Passenger's footwell.
20.		•	Steering wheel taken perpendicular to driver's side.
21.		•	Driver right knee impact point.
22.		•	Driver left knee impact point.
23.		•	Passenger knee impact area.

8 VIRTUAL TESTING

The videos shall meet all of the requirements detailed in Section 2.1.4.

8.1 Far Side

8.1.1 Videos of the animated simulations

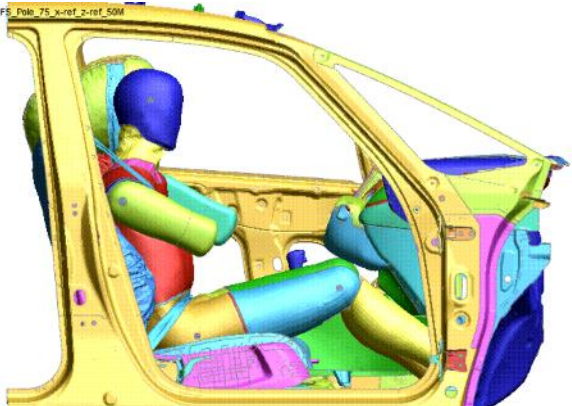
 <p>FS_Pole_75_x-ref_z-ref_50M</p>	View:	1
	Filename:	1_FS_Pole_75_x-ref_z-ref_50M_Sim_1_side
	Description:	Side view of occupant and BIW

 <p>D3PLOT: 1_1_FS_Pole_75_x-ref_z-ref_50M</p>	View:	2
	Filename:	2_FS_Pole_75_x-ref_z-ref_50M_Sim_1_front
	Description:	Front view positioned in front of occupant, both seats in frame

 <p>D3PLOT: 1_1_FS_Pole_75_x-ref_z-ref_50M</p>	View:	3
	Filename:	3_FS_Pole_75_x-ref_z-ref_50M_Sim_1_front_centre
	Description:	Front view positioned on vehicle centreline, both seats in frame

	View:	4
	Filename:	4_FS_Pole_75_x-ref_z-ref_50M_Sim_1_front_belt
	Description:	Front view positioned in front of occupant, aimed at seatbelt

	View:	5
	Filename:	5_FS_Pole_75_x-ref_z-ref_50M_Sim_1_top
	Description:	Plan view positioned on vehicle centreline, both seats in frame

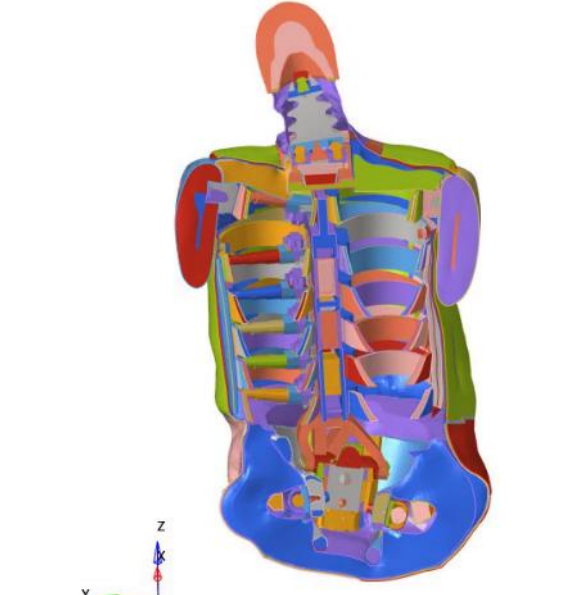
	View:	6
	Filename:	6_FS_Pole_75_x-ref_z-ref_50M_Sim_1_X-section
	Description:	<p>The coronal cutting plane must be normal to the x-axis and cut through the dummy pelvis and the sternum. The aim is to have a detailed view of the lumbar spine kinematics.</p> <p>The cross-section cut shall be fixed relative to the dummy and move with the dummy throughout the simulation.</p>

8.2 Frontal Impact

Animations of all cases detailed in the VTC protocol must be provided. The filename examples provided below need to be adjusted according to the specific load case and the respective dummies positioned on the driver and passenger seat.

The filenames follow the following scheme:

<loading direction>_<pulse severity>_<coordinate axis 1>_<coordinate axis 2>_<driver dummy>_<passenger dummy>_<view>

An example would be "FI_50kph_x-ref_z-ref_50M_95M_right"

8.2.1 Videos of the animated simulations

Where separate driver and passenger models are used, all views defined below shall be provided for both the driver and passenger occupants.

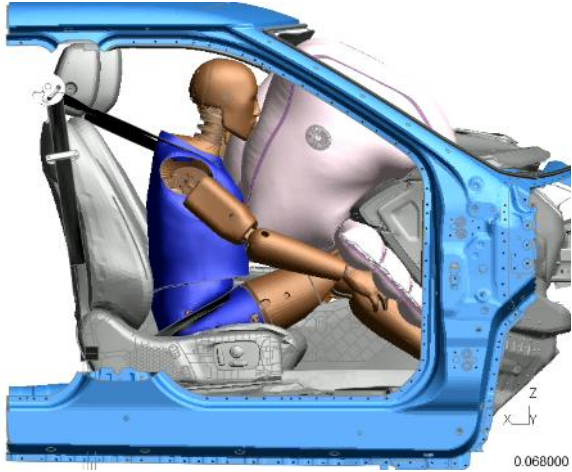
 <p>A 3D simulation showing a right-side view of a car's interior. Two crash test dummies are seated in the front seats. The driver dummy is on the left, wearing a blue vest, and the passenger dummy is on the right, wearing a pink vest. The car's blue body-in-white (BIW) is visible around the seats. A coordinate system with x, y, and z axes is shown in the bottom right corner of the image, along with the number 0.068000.</p>	View:	1
	Filename (example):	1_FI_50kph_x-axis_z-axis_50M_95M_right
	Description:	Right-side view of occupants and BIW

 <p>A 3D simulation showing a left-side view of a car's interior. Two crash test dummies are seated in the front seats. The driver dummy is on the left, wearing a red vest, and the passenger dummy is on the right, wearing a blue vest. The car's blue body-in-white (BIW) is visible around the seats. A coordinate system with x, y, and z axes is shown in the bottom right corner of the image, along with the number 0.00000000.</p>	View:	2
	Filename (example):	2_FI_50kph_x-axis_z-axis_50M_95M_left
	Description:	Left-side view of occupants and BIW



View:	3
Filename:	3_FI_50kph_x-axis_z-axis_50M_95M_front
Description:	Front view positioned in front of occupants, both seats in frame

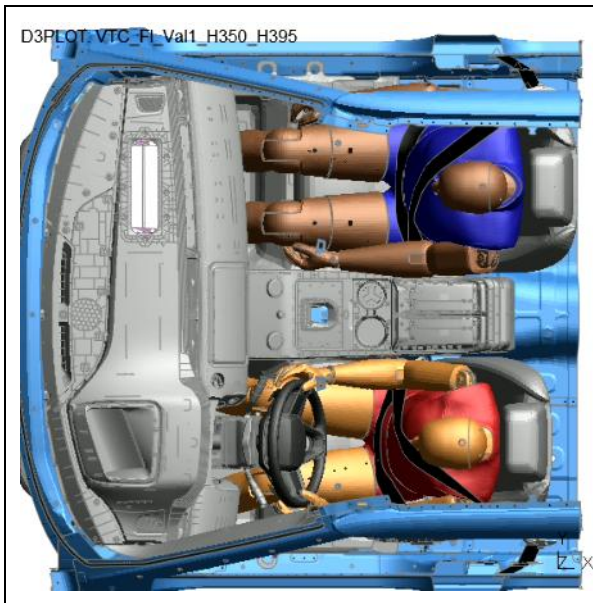

View:	4
Filename:	4_FI_50kph_x-axis_y-axis_50M_95M_top
Description:	Top view positioned above the occupants, both seats in frame



View:	5 (on-board)
Filename:	5_FI_50kph_50M_95M_Driver_onboard
Description:	Driver seat, belt buckle and majority of driver dummy should be in view.

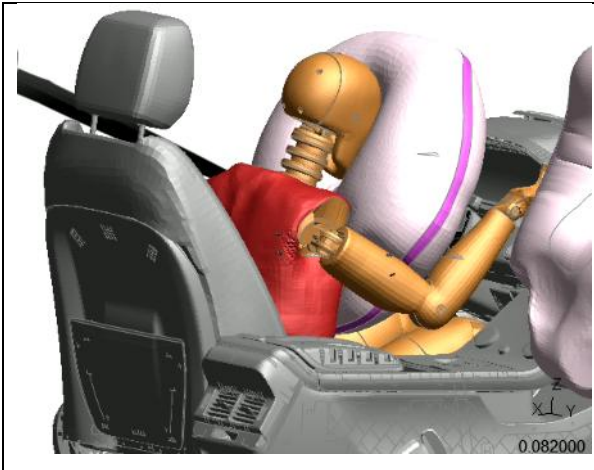

--	--

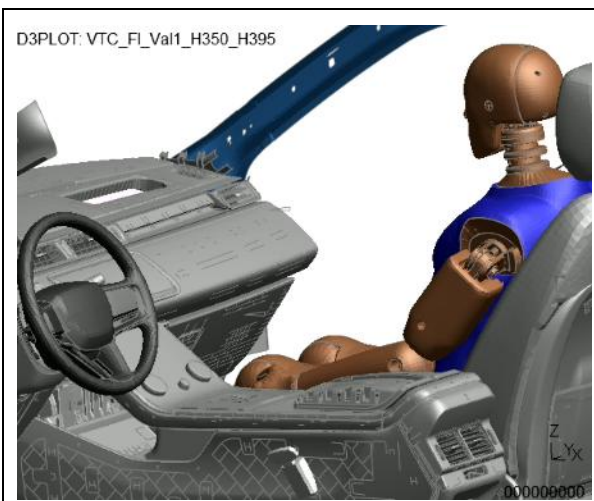

View:	6 (on-board)
Filename:	6_FI_50kph_50M_95M_Passenger_onboard
Description:	Passenger seat, belt buckle and majority of passenger dummy should be in view.



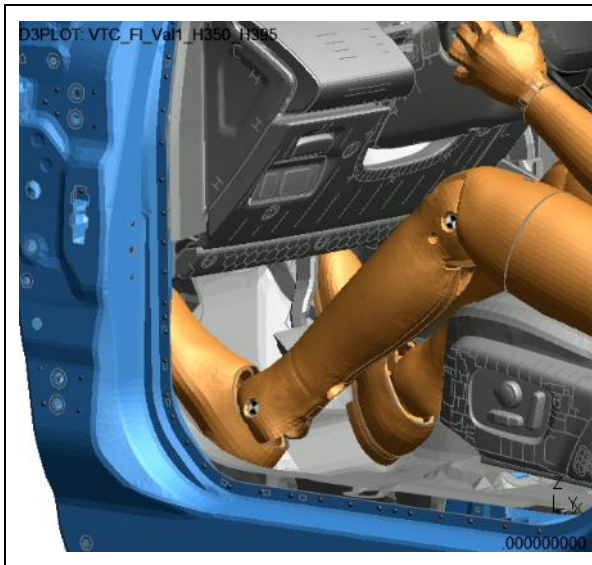

View:	7
Filename:	7_FI_50kph_50M_95M_Driver_footwell
Description:	Driver footwell

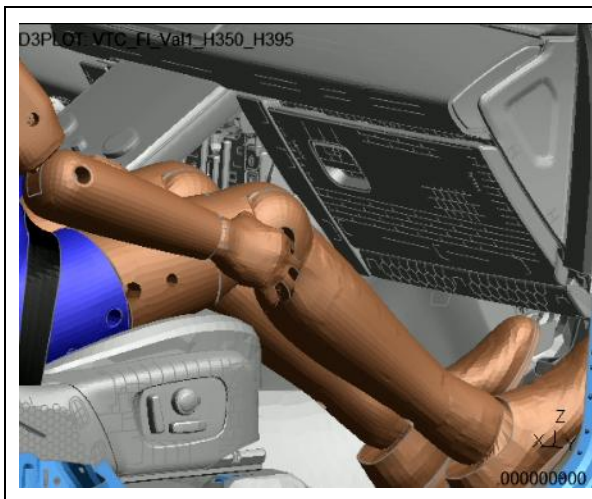

View:	8
Filename:	8_FI_50kph_50M_95M_Passenger_footwell
Description:	Passenger footwell

9 REAR IMPACT WHIPLASH TESTS

9.1 Sled, Seat and Dummy Markings

In order to monitor the seat and the dummy film targets should be applied to seat, sled and dummy. Targets should be securely affixed to areas of the seat which will not be deformed by the dummy during the test. The required target definitions are illustrated in Figure 7a and b are given along with their reference points in Table 9. A plain light coloured, even surface and non-reflective screen or wall should be placed behind the sled with the Euro NCAP logo and the official test reference number below clearly in view.

In order to track the trajectories of the dummy and seat with reference to the sled the dimensions in Table 10, Figure 7b should be recorded. All measurements shall be measured from the camera film plane to the reference targets and recorded in mm.

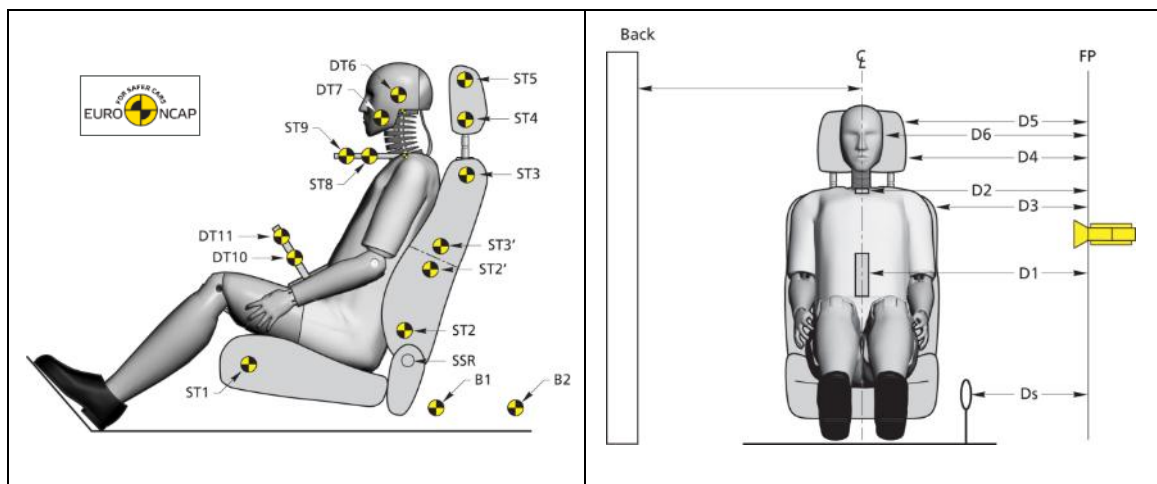

Figure 7: (a) Video motion targets and Euro NCAP label placement, left;
(b) Video tracking measurements, right.

Table 9: Video motion target placement description (Whiplash).

Designation	Description
B1	Sled base #1
B2	Sled base #2
DT6	Head CoG
DT7	Cheek
DT8	T1 bracket proximal
DT9	T1 bracket distal
DT10	Pelvis bracket proximal
DT11	Pelvis bracket distal
ST1	Seat base forward
ST2	Seat back lower
ST2'	Seat back mid #1 *

ST3	Seat back upper
ST3'	Seat back mid #2 *
ST4	Lower head restraint
ST5	Upper head restraint
SRR	Seat recliner centre

* These target locations are required only for 2 part hinged seatbacks.

Table 10: Video tracking measurement description (Whiplash).

Description	Measure	Reference
DS	Sled reference to focal plane	Sled – FP
D1	Pelvis to focal plane	DT11 – FP
D2	T1 bracket to focal plane	DT9 – FP
D3	Seatback upper to focal plane	ST3 – FP
D4	Head restraint lower to focal plane	ST4 – FP
D5	Head restraint upper to focal plane	ST5 – FP
D6	Head CoG to focal plane	DT6 - FP

9.2 Camera Locations and Views

Two cameras are required (with acceleration sled system):

Camera 1: The camera shall record a view of the entire test and the seat on the sled. The view should be such that 300ms of the test are in complete view from T0.

Camera 2: The camera shall frame the head and neck of the dummy, and track the entire movement of the dummy during the test. The view should be such that 300ms of the test are in complete view from T0.

Care should be taken to ensure that camera placement is perpendicular to the direction of sled travel. Camera measurements should be taken to the film plane of the camera, from both the fixed targets and the head Centre of Gravity target. For off board camera views, compensation must be included in the film analysis to take account of parallax effects due to sled motion relative to the cameras.

Table 11: List of camera views (Whiplash).

	Camera:	1
	Filename:	1_Whiplash_Wide_publication
	Description:	Wide view showing all of seat and dummy including seat mounting & toeboard area.

	Camera:	2
	Filename:	2_Whiplash_tight
	Description:	Verify whether Euro NCAP logo and test reference number are in view.

9.3 Still Photographs

The following photographs will be taken pre and post-test unless otherwise indicated. Pre-test photographs will be taken with the dummy in the final position.

Table 12: List of photos (Whiplash).

No.	Pre	Post	View
1	•	•	Seat structure reference point
2	•	•	Seat track markings (both sides)
3	•	•	Close view of Head restraint test position (identifiable point and any visible notches)
4	•	•	Dummy and seat at 45 degrees to rear
5	•	•	Side view of dummy and seat
6	•	•	Dummy and seat at 45 degrees to front
7	•	•	Front view of dummy and seat
8	•	•	Front view of dummy showing top of head down to knees
9	•	•	Dummy head down to thorax and seat at 45 degrees to rear
10	•	•	Dummy head down to thorax and seat at 20 degrees to rear
11	•	•	Side view of dummy head down to thorax
12	•	•	Dummy head down to thorax and seat at 45 degrees to front
13	•	•	Dummy head down to thorax and seat at 20 degrees to front
14	•	•	Side view of dummy showing thorax down to feet, camera centred on seat base
15	•	•	Tight side view of dummy showing thorax down to feet, camera centred on seat base
16	•	•	Side view of dummy and seat (portrait) showing seat back to knees
17	•	•	Tight side view of dummy and seat (portrait) showing seat back to pelvis
18		•	Any damage to seat (multiple aspects required)
19		•	Any damage to dummy (multiple aspects required)
20		•	Seat variant and trim condition (multiple aspects required)
21		•	Seat adjustment controls (multiple aspects required)

Screen Captures / On Test Stills:

In addition to the pre- and post-test stills, a picture captured during travel needs to be provided, as follows: (1) high severity pulse - maximum seat deflection.

10 VULNERABLE ROAD USER SUBSYSTEM TESTS

10.1 Vehicle and Other Markings



To hide any background test equipment or personnel, a plain light coloured, non-reflective screen should be placed near (behind) the vehicle test area with the Euro NCAP logo and official test reference number clearly visible in view. Test house logos and/or test number may be shown provided that they do not detract attention from the Euro NCAP markings (see Section 2.2.2). There should be no markings on the vehicle, including test house logos.

10.2 Camera Locations and Views

A single camera is required to record the impact events. The camera orientation should be aligned perpendicular to the vehicle centreline and adjusted in height in accordance with the type of test. Euro NCAP requires at least one HD quality high speed film recording per VRU impactor type for each vehicle model tested (4 in total).

Care should be taken that the test area is sufficiently lit.

Table 13: List of camera views (VRU Subsystem).

	Camera:	1
	Filename:	1_Lower_leg_publication
	Description:	Camera perpendicular to vehicle centreline @ T0. Launcher plate should be visible. Left or right side views are allowed.
	Camera:	2
	Filename:	2_Upper_leg_publication
	Description:	Camera perpendicular to vehicle centreline @ T0. Impactor should be completely visible. Left or right side views are allowed

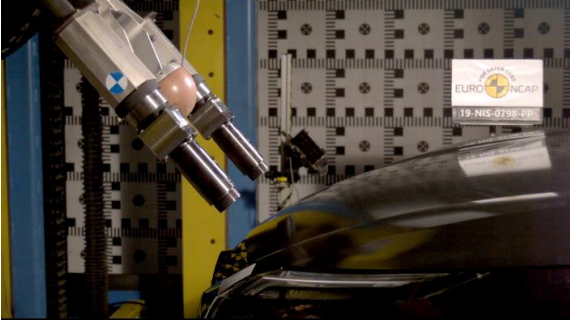
	Camera:	3
	Filename:	3_Ped_child
	Description:	<p>Camera perpendicular to vehicle centreline @ T0.</p> <p>Left or right side views are allowed.</p>

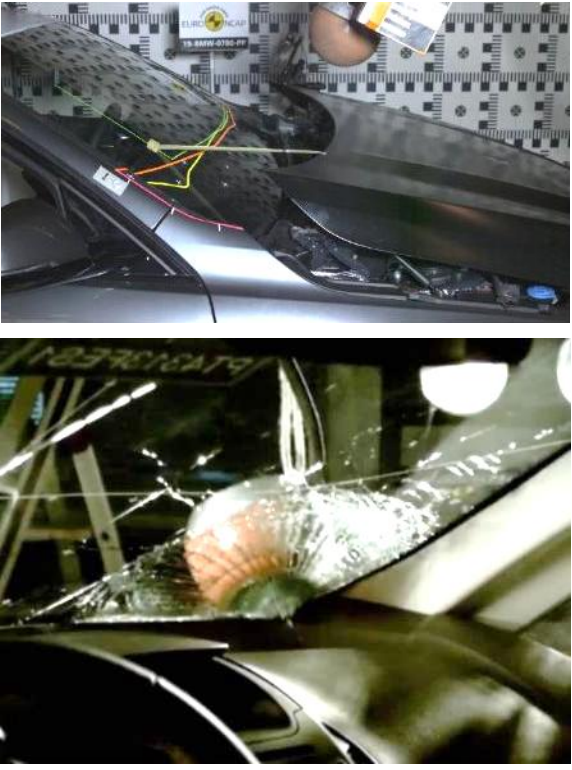
	Camera:	4
	Filename:	4_Ped_adult
	Description:	<p>Camera perpendicular to vehicle centreline @ T0. Left or right side views are allowed.</p> <p>Tests on windscreen may alternatively be filmed from the vehicle inside.</p>

10.3 Still Photographs

Pre- and post-test photos should be taken to show the undamaged/damaged test area pre/post-test (bonnet, A-pillars, glazing, leading edge and bumper). These must include at least one overview photo of each of the pre-test grid markings on the impact test zones.

For VRU testing only inspection quality photos are required by Euro NCAP.

Table 14: List of photos (VRU).

No.	Pre	Post	View
1	•		Full vehicle Left side
2	•		Full vehicle Right side
3	•		Front third vehicle Left side
4	•		Front third vehicle Right side
5	•		Full vehicle Front
6	•		Left half vehicle Front
7	•		Right half vehicle Front
8	•		Front third of vehicle Top
9	•		Front third, right half of vehicle Top
10	•		Front third, left half of vehicle Top
11	•		Legform test points Front
12	•		Upper legform test points Front
13	•		Child head zone test points Top
14	•		Adult head zone test points Top
15		•	Legform test points Front
16		•	Legform test points Side
17		•	Upper legform test points Front
18		•	Upper legform test points Side
19		•	Child head zone test points Top
20		•	Child head zone test points Side
21		•	Adult head zone test points Top
22		•	Adult head zone test points Side