

Crash Protection

Frontal Impact

Protocol

Implementation January 2026

Copyright © Euro NCAP 2024 - This work is the intellectual property of Euro NCAP. Permission is granted for this material to be shared for non-commercial, educational purposes, provided that this copyright statement appears on the reproduced materials and notice is given that the copying is by permission of Euro NCAP. To disseminate otherwise or to republish requires written permission from Euro NCAP.

PREFACE

During the test preparation, vehicle manufacturers are encouraged to liaise with the laboratory and to check that they are satisfied with the way cars are set up for testing. Where a manufacturer feels that a particular item should be altered, they should ask the laboratory staff to make any necessary changes. Manufacturers are forbidden from making changes to any parameter that will influence the test, such as dummy positioning, vehicle setting, laboratory environment etc.

It is the responsibility of the test laboratory to ensure that any requested changes satisfy the requirements of Euro NCAP. Where a disagreement exists between the laboratory and manufacturer, the Euro NCAP secretariat should be informed immediately to pass final judgment. Where the laboratory staff suspect that a manufacturer has interfered with any of the set up, the manufacturer's representative should be warned that they are not allowed to do so themselves. They should also be informed that if another incident occurs, they will be asked to leave the test site.

Where there is a recurrence of the problem, the manufacturer's representative will be told to leave the test site and the Secretary General should be immediately informed. Any such incident may be reported by the Secretary General to the manufacturer and the person concerned may not be allowed to attend further Euro NCAP tests.

DISCLAIMER: Euro NCAP has taken all reasonable care to ensure that the information published in this protocol is accurate and reflects the technical decisions taken by the organisation. In the unlikely event that this protocol contains a typographical error or any other inaccuracy, Euro NCAP reserves the right to make corrections and determine the assessment and subsequent result of the affected requirement(s).

NOTE: All 2026 protocols with a version number 0.9 are under final review of the Working Group and might undergo minor changes.

CONTENTS

SCORING	1
1 MEASURING EQUIPMENT	2
1.1 Reference system	2
1.2 Dummies	2
1.3 Collision partners	2
1.4 Measurements and variables	3
2 TEST CONDITIONS	5
2.1 VUT preparation	5
2.2 Test overview	5
2.3 Occupant compartment adjustments	5
2.4 Dummy positioning and measurement	9
2.5 CRS installation and child dummy placement	16
2.6 Determining limited rear space	19
3 TEST PROCEDURE	21
3.1 Summary	21
3.2 Colour band scheme	21
3.3 Injury criteria and limits	22
3.4 MPDB	25
3.5 FWT	25
3.6 Virtual testing and sled	26
4 POST-TEST ASSESSMENT & INSPECTION	27
4.1 After test	27
4.2 Intrusion measurements	27
4.3 Barrier face measurement	27
4.4 Inspection	30
4.5 Scoring and visualisation	32

SCORING

Crash Protection – Frontal Impact		Total points 40
Offset test		20
Driver – THOR 50 th male		5
Front passenger – HIII 5 th female		5
Rear passenger – Q6		5
Rear passenger – Q10		5
Full width test		10
Driver – HIII 5 th female		5
Front passenger – THOR 50 th male		2.5
Rear passenger – HIII 5 th female		2.5
Sled & virtual testing		10
Driver		5
Sled – 50km/h – HIII 50 th male		
Sled – 56km/h – HIII 95 th male		
VTC – 35km/h – HIII 50 th male		
VTC – 35km/h – HIII 5 th female		
VTC – 56km/h – HIII 5 th female		
Front passenger		5
Sled – 50km/h – HIII 95 th male		
Sled – 56km/h – HIII 5 th female		
VTC – 35km/h – HIII 5 th female		
VTC – 35km/h – HIII 50 th male		
VTC – 56km/h – HIII 95 th male		

Definitions used in this protocol can be found in Euro NCAP Technical Bulletin TB 045.

1 MEASURING EQUIPMENT

1.1 Reference system

The sign convention used for configuring the transducers is stated in SAE J211 (2007).

1.2 Dummies

All Anthropometric test Devices (ATD) shall conform to the specifications detailed in the respective Technical Bulletins below:

Test	ATD
MPDB & FWT	THOR 50 th percentile male TB 026 Hybrid III 5 th percentile female TB 048 Q6 and Q10 child TB 053
Sled validation 1	Hybrid III 50 th percentile male TB 049 Hybrid III 95 th percentile male TB 050
Sled validation 2	Hybrid III 5 th percentile female TB 048 Hybrid III 95 th percentile male TB 050

1.3 Collision partners

1.3.1 MPDB

The trolley will be fitted with the Progressive Deformable Barrier (PDB) conforming to the specifications of Technical Bulletin TB 022.

The Mobile Progressive Deformable Barrier (MPDB) includes both an impactor and a trolley. The trolley shall meet the specification detailed in TB047.

1.3.2 Full width test

The wall shall be fitted with the Full Width Deformable Barrier Face conforming to the specifications of Technical Bulletin TB 042.

The barrier shall consist of a block of reinforced concrete not less than 3m wide in front and not less than 1.5m high. The barrier shall be of such thickness that it weighs at least 70 metric tons. The front face shall be flat, vertical and perpendicular to the axis of the run-up track. It may be covered with plywood boards 20 ± 2mm thick to prevent damage to the mounting face. When used, the plywood shall be in good condition.

The barrier face shall be mounted with the lower edge of the honeycomb 80mm above ground level. It is important to ensure that all vehicle structures impact the barrier face and not the surrounding wall. If the impact area of the test vehicle were likely to exceed the upper edge of the deformable element, the height of the barrier may be increased. Alternatively, a taller deformable element shall be used.

1.4 Measurements and variables

1.4.1 Instrumentation general

All instrumentation used in the test shall be (re-)calibrated within at least one year before each test and should be re-calibrated if it reaches its CAC during any test.

The measurement data shall be recorded according to ISO 6487 or SAE J211/1 at a minimum sample frequency of 20kHz.

1.4.2 VUT instrumentation

The vehicle is to be fitted with an accelerometer on each B-post in the fore/aft direction (A_x). Ensure the accelerometer is horizontal to a tolerance of ± 1 degree and parallel to the X-axis of the vehicle.

Attach lightweight (<100g) seatbelt loadcells to the shoulder section of the relevant seatbelts. The calibration procedure for the loadcells is detailed in TB 016. Where the fitment of the shoulder belt loadcell significantly influences the natural position of the belt, the loadcell may be supported from above with the use of a weak non-metallic wire or thread. Where loadcells are to be placed on any seatbelts equipped with pretensioners, ensure that the loadcell is placed far enough away from the D-loop to ensure there is no interaction as the pretensioner fires. Where any CRS lock-off does not allow the loadcell to be placed a sufficient distance from the D-loop do not attach the loadcell.

Location	Parameter	CAC
B-Post LHS & RHS	Acceleration, A_x	150g
Driver's seatbelt shoulder section	Force, F_{diagonal}	16kN
Row 1 Passenger's seatbelt shoulder section	Force, F_{diagonal}	16kN
Row 2 Passenger's seatbelt shoulder section	Force, F_{diagonal}	16kN
Q10 Seatbelt shoulder section	Force, F_{diagonal}	16kN
Q6 Seatbelt shoulder section	Force, F_{diagonal}	16kN
Battery, including secondary batteries	Supply voltage, V	15V

1.4.3 MPDB trolley instrumentation

Location	Parameter	CAC
Trolley C of G	Acceleration, A_x A_y A_z	150g
Trolley C of G, backup sensor	Acceleration, A_x A_y A_z	150g

1.4.4 PDB face measurement

For measuring the deformation of the PDB barrier a 3D measuring system shall be used (e.g. 3D measurement arm with attachable scan module). This system must be capable of recording three dimensional co-ordinates of single points, as well as clouds of points (scanner). A tolerance of **+/- 1mm** is applicable to such a system.

Measure the four corner points of the undeformed barrier front plane.

Set up an axis system using the following elements:

- Point (point of origin): Lower right corner (seen from direction of motion)
- Vector (Y): from the left lower corner point to the right lower corner point
- Plane (YZ): best-fit plane from all four corner points

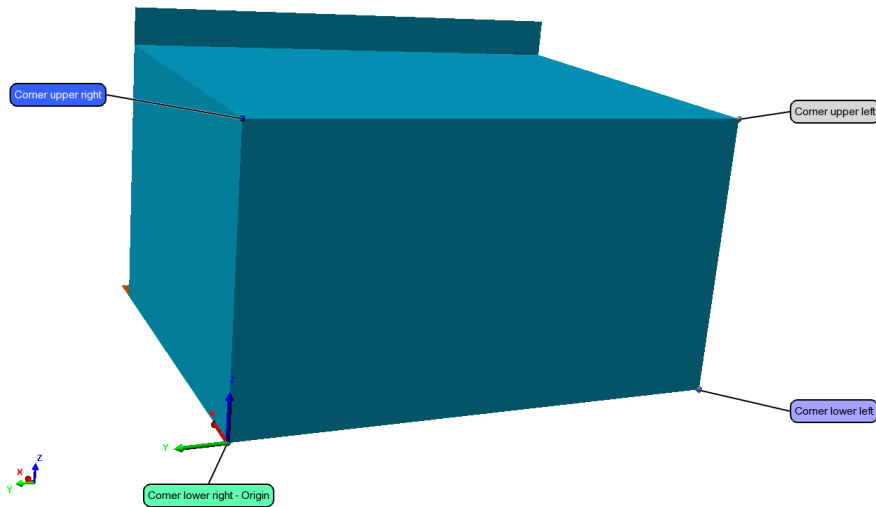

Mark and measure at least four reference points each on the left and right side of the barrier back plate where the sheet metal is folded up to build a stiff border. The points shall be spread over the whole length of the border and placed in different height levels to allow a proper realignment of the measurement system after crash.



Mark and measure at least four reference points on the non-struck side rear honeycomb layer. Refer to Section 4.3 for posttest barrier face measurements.

2 TEST CONDITIONS

2.1 VUT preparation

In advance of test preparation, the OEM shall provide Euro NCAP and the test laboratory with the information detailed in Technical Bulletin TB 018. Prepare the vehicle as defined in Technical Bulletin TB 046 and perform pretest intrusion measurements.

2.2 Test overview

An overview of the Euro NCAP full scale tests and OEM sled tests is detailed below.

	Full scale testing		Sled & simulation	
	MPDB	FWT	Validation 1	Validation 2
Severity	50km/h	35km/h	50km/h	56km/h
1 st row driver	THOR 50 th	HIII 5 th female	HIII 50 th male	HIII 95 th male
1 st row passenger	HIII 5 th female	THOR 50 th	HIII 95 th male	HIII 5 th female
2 nd row driver	Q6	-		
2 nd row passenger	Q10	HIII 5 th female		

2.3 Occupant compartment adjustments

Position the seats as detailed below. Adjustments not listed will be set to mid positions or nearest positions rearward, lowest or outboard.

2.3.1 50th percentile male occupants

Adjustment	Required setting – THOR and Hybrid III
Fore/aft	Mid position between fully forward and 95 th otherwise first notch rearwards.
Front seat cushion tilt	MDP permissible up to mid, otherwise lowest.
Front seat height	Lowest position
Front seat torso angle	MDP otherwise 25° torso angle
Front seat lumbar support	Fully retracted
Front seat cushion length	Fully retracted

Adjustment	Required setting – THOR and Hybrid III
Front head restraint	Height: Mid position, when there is contact with the dummy move to highest. See TB 028. Fore/aft or tilt: Mid position, when the headrest pushes the head forward, move to most rearward. See TB 028.
Front seat belt anchorage	MDP otherwise mid. Must not be below mid and webbing must ideally not be in contact with the neck
Arm-rests	Not in use position, see TB 028. This position is to avoid interference with view of the pelvis. The arm rest may be fixed to avoid movement during the test.

2.3.2 5th percentile female occupants – front only

Adjustment	Required setting – Hybrid III
Fore/aft	Driver - MDP permissible between fully forward and 25% of travel, measured in lowest position otherwise fully forwards Front passenger - Mid between fully forward and 95th, measured in lowest position
Front seat cushion tilt	MDP permissible up to mid, otherwise mid.
Front seat height	MDP permissible between fully upward and 75% travel downwards, when in 5 th percentile fore/aft position
Front seat torso angle	MDP otherwise 25° torso angle
Front seat lumbar support	MDP otherwise fully retracted
Front seat cushion length	Fully retracted
Front head restraint	Height: Lowest position, when there is contact with the dummy move to highest. See TB 028. Fore/aft or tilt: MPD, otherwise mid position, when there is contact with the dummy move to most rearward. See TB 028.
Front seat belt anchorage	Lowest
Arm-rests	Not in use position, see TB 028. This position is to avoid interference with view of the pelvis. The arm rest may be fixed to avoid movement during the test.

2.3.3 95th percentile male occupants

Adjustment	Required setting – Hybrid III
Fore/aft	MDP (95 th)
Front seat cushion tilt	MDP permissible up to mid, otherwise mid.
Front seat height	Lowest position
Front seat torso angle	MDP otherwise 25° torso angle
Front seat lumbar support	MDP otherwise fully retracted
Front seat cushion length	Fully retracted
Front head restraint	Height: Highest position, when there is contact with the dummy move to highest. See TB 028. Fore/aft or tilt: MDP, otherwise mid position, when there is contact with the dummy move to most rearward. See TB 028.
Front seat belt anchorage	Highest. Webbing must not be in contact with the neck.
Arm-rests	Not in use position, see TB 028. This position is to avoid interference with view of the pelvis. The arm rest may be fixed to avoid movement during the test.

2.3.4 Rear seats

Adjustment	Required setting Must be the same for MPDB, FWT and AE-MDB
Rear seat facing	Forwards
Rear seat lateral position	Most outboard
Rear seat fore/aft	Rearmost
Rear seat cushion tilt	MDP up to mid position, otherwise lowest
Rear seat height	MDP up to mid position, otherwise lowest
Rear seat back angle	MDP otherwise 25° torso angle
Rear seat lumbar support	Fully retracted
Rear seat cushion length	Fully retracted
Rear head restraint	Height: Lowest. When there is contact with the dummy head or child/CRS move to highest. Fore/aft or tilt: MDP, otherwise mid position, when there is contact with the child/CRS move to most rearward. See TB 028. Remove if the vehicle handbook allows for CRS use.

Adjustment	Required setting Must be the same for MPDB, FWT and AE-MDB
Rear seat belt anchorage	MDP otherwise mid
Arm-rests (Rear seats)	Not in use position, see TB 028. This position is to avoid interference with view of the pelvis. The arm rest may be fixed to avoid movement during the test.

2.3.5 Other settings

Other settings	Required setting
Steering wheel	50 th percentile - mid vertical and horizontal 5 th percentile – MDP otherwise mid vertical and horizontal with a minimum horizontal distance to the dummy of 250mm measured from the centre of the steering wheel. 95 th percentile – MDP otherwise mid vertical and horizontal
Side window glazing	Front – lowered. Rear - lowered or removed
Gear change lever	In the neutral position
Parking brake	Disengaged
Pedals	Normal position of rest or MDP for adjustable pedals
Doors	Closed. Rear child locks disengaged. See Post Crash protocol for ADL requirements (locking etc.)
Roof	Lowered / stowed
Sunroof	Open or removed
Sun visors	Stowed
Rear view mirror	Normal position of use
Front passenger airbag	Enabled – Vehicles equipped with automatic airbag disabling and default OFF may require specific actions to deploy airbag.

2.4 Dummy positioning and measurement

It is the intention that the dummy is not left to sit directly on the seat for more than 2 hours prior to the test. It is acceptable for the dummy to be left in the vehicle for a longer period, provided that the dummy is checked no more than one hour prior to test. It is not acceptable for the dummy to be left in the vehicle overnight or for a similarly lengthy period.

Measure the location of the H-point manikin for the 50th percentile male using the procedure defined in UN ECE R135, Annex 4, Section 7.

Measure the location of the H-point manikin for the 5th percentile female using the procedure defined in UN ECE R137, Annex 5, Section 3.

2.4.1 Dummy Placement

If, after dummy positioning, the vehicle is moved or a test run is aborted ensure that the dummy has not moved from the intended pretest position. If there are difficulties with positioning of any dummy, the H-point location shall be the priority followed by the pelvic angle and then the torso angle.

2.4.2 THOR dummy positioning – MPDB & FWT

The seat settings shall not be adjusted for dummy positioning with the exception of the fore/aft travel to establish the knee gap where required. If the dummy cannot be positioned within the tolerances below after three attempts, then it is to be placed as close to the tolerance limits as possible.

Dummy part	Required setting
H-point	Within a square of $\pm 13\text{mm}$ in X and Z of a point 20mm upward and 20mm forwards of the manikin H-point of the 50 th percentile male.
Pelvic angle	Tilt sensor shall read $0^\circ \pm 1^\circ$ (X) and $33^\circ \pm 2.5^\circ$ (Y).
Torso angle	T1 neck tilt sensor $0^\circ \pm 1^\circ$ (X) and $\pm 1^\circ$ (Y) with respect to the manufacturers neck T1 design angle. The THOR torso angle might be different to the H-point manikin design angle. The dummy's back shall be in contact with the seat back and the centre line of the dummy shall be lined up with the centre line of the seats. Push the shoulders fully rearward by hand.
Head	If there is contact between the head restraint and head that does not result in forwards movement of the CoG, do not adjust head restraint. If the head CoG is pushed forwards by the head restraint, firstly move the head restraint rearwards in X, then in Z if required. If there is still interference and no further adjustment of the head restraint is possible continue with the test.
Upper arms	Driver - Adjacent to the torso as far as is possible. Passenger - Adjacent to the torso and against the seat back.
Hands	Driver - Palms placed against the steering wheel at a position of a quarter to three. The thumbs should be lightly taped to the steering wheel, where applicable, for the test. Passenger - Hands against the outside of the upper leg.

Dummy part	Required setting
Legs	<p>If the knees are in contact with the fascia or the gap is less than 30mm, move the dummy and seat rearwards until a gap of 30mm is achieved, or to the nearest notch rearwards. It must be possible to pass a sphere of 30mm diameter between the knee clevis flesh and fascia (the tibia flesh shall be ignored). Record the new H-point location within the test details.</p> <p>The femurs shall be in contact with the seat cushion as far as possible. Set the initial distance apart of the outboard metal surfaces of the knee clevis flanges of each dummy to 270mm ± 10mm. When the left foot is placed on a footrest or the right foot is positioned onto the accelerator pedal as described below, the initial distance between the knees may be ignored. The femur and tibia for each leg shall be as close as possible to a vertical plane.</p>
Feet	<p>Driver - The right foot shall rest on the undepressed accelerator pedal with the heel on the floor. To keep the upper and lower legs in the same vertical plane, move the upper leg accordingly.</p> <p>If the foot cannot be placed on the pedal then it should be placed as far forwards as possible with the foot perpendicular to the lower tibia, in line with the centre line of the pedal. If a dedicated footrest is present, place the left foot fully on this rest providing a normal seating position can still be achieved. Keep the legs in the same vertical plane.</p> <p>The knee gap requirement of 270mm ± 10mm may be ignored in this case. Where there is no footrest, position the left foot at an equal distance from centre line of seat as the right leg is from centreline. The left foot should be placed as flat as possible on the toe-board parallel to the centreline of the vehicle. Note the knee gap in the test details.</p> <p>Passenger - The feet shall be placed with the heel as far forwards as possible with the feet as flat on the floor. Both feet shall be parallel to the centreline of the vehicle.</p>

2.4.3 5th percentile female passenger dummy placement - MPDB

Dummy part	Required setting
H-point	Within a square of ±13mm in X and Z of the manikin H-point of the 5 th percentile female, with a point 6 mm below the position of the H-point determined using the procedure described in R137 Annex 6.
Pelvic angle	20° ±2.5° from the horizontal.
Torso angle	Dummy's back in contact with the seat back and the dummy centreline aligned with that of the seatback.
Head	<p>The transverse instrumentation platform horizontal to within ±2.5°. Levelling of the head shall be carried out in this order:</p> <ul style="list-style-type: none"> – Adjust the H-point within the limit – Adjust the pelvic angle within the limits – Adjust the neck bracket the minimum to ensure that the transverse instrumentation platform is level within limits.
Upper arms	Positioned in contact with the seatback.

Dummy part	Required setting
Hands	Palms in contact with the outside of the legs and the little finger in contact with the seat cushion.
Legs	Femurs shall be in contact with the seat cushion as far as possible. The distance between the knees of the dummy shall be 210mm ± 5mm when measured at the outside metals surface of the knees. The femur and tibia for each leg shall be as close as possible to a vertical plane.
Feet	Placed with the heel as far forwards as possible and then the feet as flat as possible. Both feet shall be parallel to the centreline of the vehicle.

2.4.4 5th female driver dummy positioning - FWT

Dummy part	Required setting
H-point	Within a square of ±13mm in X and Z of the manikin H-point of the 5 th percentile female, with a point 6 mm below the position of the H-point determined using the procedure described in R137 Annex 6.
Pelvic angle	20° ±2.5° from the horizontal.
Torso angle	Dummy's back in contact with the seat back and the dummy centreline aligned with that of the seatback.
Head	The transverse instrumentation platform shall be horizontal to within ±2.5°. Levelling of the head shall be carried out in this order: <ul style="list-style-type: none"> – Adjust the H-point within the limit – Adjust the pelvic angle within the limits – Adjust the neck bracket the minimum to ensure that the transverse instrumentation platform is level within limits.
Upper arms	Adjacent to the torso as far as is possible
Hands	Palms placed against the steering wheel at a position of a quarter to three. The thumbs should be lightly taped to the wheel.
Legs	Femurs shall be in contact with the seat cushion as far as possible. The initial distance between the knees of the dummy shall be 210mm ± 5mm when measured at the outside metals surface of the knees. When the left foot is placed on a footrest or the right foot is positioned onto the accelerator pedal as described below, the distance between the knees may be altered. The legs of the dummies should be in vertical longitudinal planes as far as is possible.
Feet	One foot shall be placed on the undepressed accelerator pedal with the heel on the floor overlapping the accelerator pedal by at least 20mm.

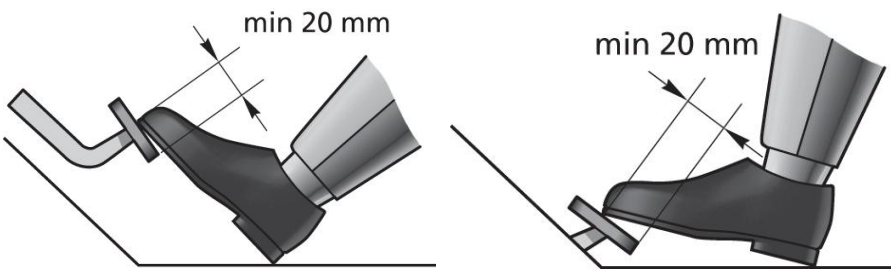
Dummy part	Required setting
	 <p>When this is not the case and the seat is not in the foremost for/aft position, move the seat forward until sufficient contact between right foot and accelerator pedal can be achieved.</p> <p>When it is not possible to achieve sufficient contact, follow the FMVSS 208 small female seating positioning procedure, where a support block is used to ensure contact with the pedal and floor. There must be no movement of the support block.</p> <p>If the right knee has been moved in order to place the right foot on the accelerator pedal, move the left knee and foot an equal distance so that the legs are symmetrical.</p> <p>The left foot should be placed as flat as possible on the toe-board parallel to the centre line of the vehicle. If any part of the left foot is in contact with a footrest or wheel arch when in this position then place the foot fully on this rest providing a normal seating position can still be achieved. Keep the legs in the same vertical longitudinal plane. The knee gap requirement may be ignored in this case.</p>

2.4.5 5th female rear passenger dummy positioning - FWT

Dummy part	Required setting
H-point	Within a square of $\pm 13\text{mm}$ in X and Z of the manikin H-point of the 5 th percentile female, with a point 6 mm below the position of the H-point determined using the procedure described in R137 Annex 6.
Pelvic angle	$20^\circ \pm 2.5^\circ$ from the horizontal. If pelvic angle cannot be achieved, use the design torso angle as a reference value.
Torso angle	Dummy's back in contact with the seat back and the dummy centreline aligned with that of the seatback.
Head	The transverse instrumentation platform shall be horizontal to within $\pm 2.5^\circ$. Levelling of the head shall be carried out in this order: <ul style="list-style-type: none"> – Adjust the H-point within the limit – Adjust the pelvic angle within the limits – Adjust the neck bracket the minimum to ensure that the transverse instrumentation platform is level within limits.
Upper arms	Positioned in contact with the seatback.
Hands	The forearms and the hands shall be positioned as close as possible to the outer sides of the thighs while the little fingers are lightly in contact with the seat cushion. If there is interference by trim or other interior parts, the interfered upper limb shall

Dummy part	Required setting
	be placed on the armrest of the same side to avoid any interference.
Legs	<p>Femurs shall be in contact with the seat cushion as far as possible. The distance between the knees of the dummy shall be $210\text{mm} \pm 5\text{mm}$ when measured at the outside metal surfaces of the knees. The legs of the dummies should be in vertical longitudinal planes as far as is possible.</p> <p>The legs shall be positioned as far as possible from the front end of the rear seat cushion while the thighs are kept in contact with the seat cushion.</p> <p>Each leg shall be lowered until the foot comes into contact with the floor while the foot and tibia are kept in a right angle to one another, the thigh inclination angle shall remain constant.</p>
Feet	<p>When each heel is in contact with the floor, the foot shall be rotated so that the toe comes as much in contact as possible with the floor.</p> <p>If it is not possible to have each foot in contact with the floor, the foot shall be lowered until the calf comes in contact with the front end of the seat cushion or the back of the foot comes in contact with the vehicle interior. The foot shall be kept as parallel as possible to the floor.</p> <p>In case of interference by front seat anchorages or by a vehicle body protrusion, the foot shall be rotated as minimally as possible around the tibia. In case interference remains, the femur shall be rotated to resolve or minimize the interference. The foot shall be moved inward or outward while the separation distance between the knees is kept constant.</p> <p>In case of significant interference by the front seat in its test position or by a vehicle body protrusion, the leg shall be moved toward the occupant side by lifting and keeping the thigh as much in contact as possible with the rear seat cushion.</p> <p>Finalisation of torso position and readjustment of foot position (if any)</p> <p>After manipulation of the lower limbs, the dummy position has to be reconfirmed in accordance with the H-point tolerances, pelvic angle and head angle. Any foot displacement during the final positioning of the torso should be undone.</p>

After manipulation of the lower limbs, the dummy position shall be reconfirmed in accordance with the H point, pelvic angle and head angle. Any foot displacement during the final positioning of the torso should be undone.

2.4.6 Seat belt – all dummies

Adjust the seatbelt D-loop for the relevant occupant as detailed in the tables above, carefully place the seat belt across the dummy and lock as normal. It will be necessary to re-position the hands as described above.

Remove the slack from the lap section of the webbing until it is resting gently around the pelvis of the dummy. Only minimal force shall be applied to the webbing when removing the slack. The route of the lap belt should be as natural as possible.

Place one finger behind the diagonal section of the webbing at the height of the dummy sternum. Pull the webbing away from the chest horizontally forward and allow it to retract in the direction of the D-loop using only the force provided by the retractor mechanism. Repeat this step three times, only.

After following the above steps, the seatbelt should lie in a natural position across the dummy sternum assembly and shoulder clavicle. Where this is not the case, and the D-loop is adjustable, the anchorage shall be adjusted and steps above repeated. For example, an unnatural position would be where the belt is in contact with the neck, neck shield or above the shoulder rotation adjustment screw (Hybrid III series only),

The upper anchorage should be adjusted by a sufficient amount to ensure a natural belt position, this may require multiple attempts.

Once the belt is positioned the location of the belt should be marked across the dummy chest to ensure that no further adjustments are made. Mark also the belt at the level of the D-loop to be sure that the initial tension is maintained during test preparation.

Where the fitment of the shoulder belt loadcell significantly influences the natural position of the belt, the loadcell may be supported from above with the use of a weak non-metallic wire or thread.

2.4.7 Dummy positioning measurements

The following measurements are to be recorded prior to the test after the dummy settling and positioning procedures have been carried out, see Figure 1.

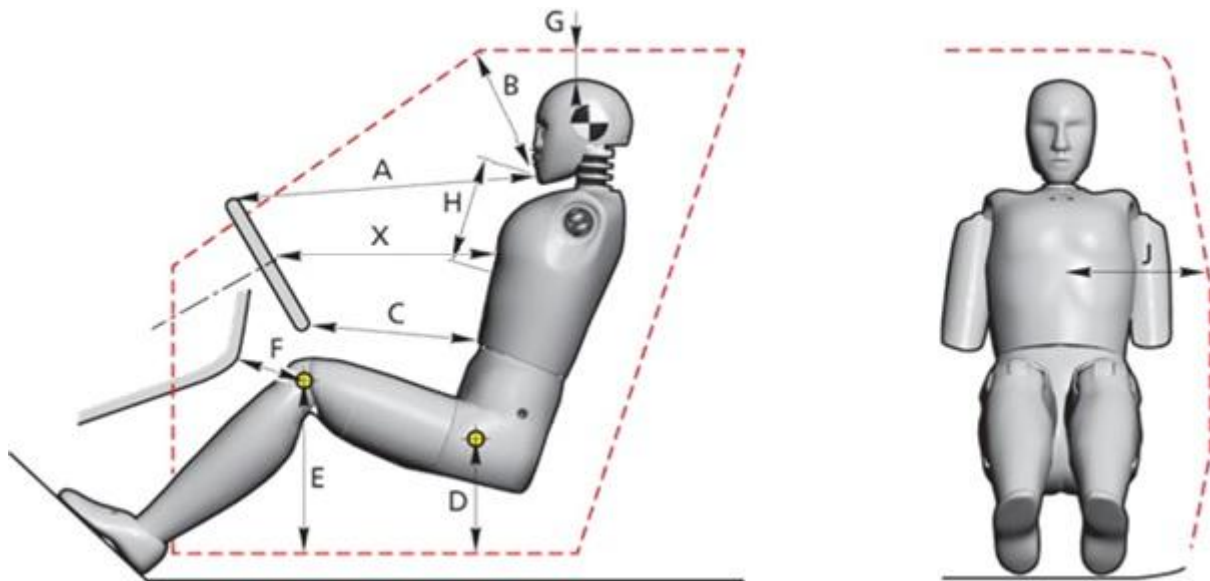

Figure 1 Dummy measurements

Driver measurements	Description
A	Chin to top of rim
B	Chin to top edge of glass
C	Stomach to rim
D	H-point to top of sill

Driver measurements	Description
E	Knee bolt to top edge of sill
F	Knee bolt to top edge of bolster
G	Head to roof surface
H	Chin to webbing (vertically)
J	Belt webbing to door (horizontally)
X	Wheel centre to chest (horizontally)
θ	Neck Angle
	H-Point Co-ordinates (to vehicle reference)
α	Seat back angle as defined by torso angle of SAE manikin
β	Head angle
γ	T1 neck
ε	Pelvic angle (x and y)

Passenger measurements	Description
A	Chin to top of rim or front passenger's seatback
B	Chin to top edge of glass
C	Stomach to facia or front passenger's seatback
D	H-point to top of sill
E	Knee bolt to top edge of sill
F	Knee bolt to top edge of bolster or front passenger's seatback
G	Head to roof surface
H	Chin to webbing (vertically)
J	Belt webbing to door (horizontally)
X	200mm below chin to closet part of facia or front passenger's seatback (horizontally)
θ	Neck Angle
	H-Point Co-ordinates (to vehicle)
α	Seat back angle as defined by torso angle of SAE manikin
ε	Pelvic angle

2.5 CRS installation and child dummy placement

The use of additional belt guides, clips or other components that are not an integral part of the CRS is prohibited. Belt guides that are fitted to the vehicle must be permanently attached and information on their use must be contained in the vehicle handbook, where this is not the case they MUST NOT be used for testing.

2.5.1 Q10 dummy installation

Attach a foam pad of 125mm x 90mm with a thickness of 20mm \pm 2mm to the rear of the dummy pelvis, outside the suit, using tape to hold it in place. The pad shall be centred on the midsagittal plane with the upper edge at the same height as the top of the pelvis flesh. This pad shall remain on the dummy for the test unless it can be removed without the need to move the dummy. The foam pad shall have the following properties:

Density of 152-200kg/m³

Compression deflection 25% of 89-118kPa

CRS/Dummy	Required setting
CRS	Place the booster cushion on the relevant seating position and mark the fore/aft position on the side of the CRS and vehicle. Align the CRS with the vehicle seat centreline and check that there is no interaction between the CRS and side door when it is closed. If there is interaction, the CRS may be moved inboard by up to 50mm. If an ISOFIX CRS is used no markings are needed, the CRS shall be aligned with the anchorages and engaged with the vehicle.
Q10 placement	<p>Place the dummy on the CRS with both aligned to the seat centreline. Ensure that the suit has not moved in the gap between femur and hip by pulling the suit towards the knees.</p> <p>Buckle the seatbelt. If the buckle is not accessible because of interaction with the CRS, move the CRS and dummy outwards as little as possible (max 50mm) to get free access to the buckle. Remove the slack from the webbing but do not tighten the webbing.</p> <p>Realign the CRS with the marks on the vehicle seat. If the CRS cannot easily be aligned with the original marks due to the shape of the vehicle seat or position of the seat belt buckle, then re-mark the new lateral position of CRS relative to vehicle seat.</p> <p>Ensure that the rear of the CRS is in contact with the seat back by pressing the CRS backwards against the seat and making sure that the fore/aft markings are still aligned.</p> <p>Where applicable, place the hip shields on the Q10 dummy. Ensure that the distance between the hip shields is no less than 154mm. If needed, a large gap should be used to establish the best fit.</p>
Torso	<p>Ensure that the dummy's lower back is in contact with the vehicle seat back by bending the dummy's back into an upright position and then rocking the dummy sideways while at the same time pushing the pelvis backwards.</p> <p>Ensure that the booster cushion is aligned with the new reference marks and that the dummy is on the centreline of the CRS and not rotated about the vertical axis.</p> <p>Push the dummy's shoulders toward the seat back until either the shoulders contact the seat back or the head is in contact with the head restraint.</p>

CRS/Dummy	Required setting
	<p>The top of the rear head restraint shall be positioned within ± 20mm of the top of the dummy head or in the nearest notch above. If the head restraint cannot be raised sufficiently to be within 20mm, put it in the highest position.</p> <p>Ensure that the dummy is sitting in an upright position and is aligned with the centreline marks on the head restraint (if applicable) or is parallel to the marks of the centreline.</p> <p>Ensure that the CRS position did not change relative to the marked position</p>
Arms	<p>The upper arm shall be positioned parallel to the chest. The measurements shall be taken on the neoprene suit along the front surface of the arm (bicep) and between the two IR-TRACCs on the chest.</p> <p>Position the lower arms parallel to the upper legs resting on the booster cushion or armrest as close as possible to the side of the femur. The elbows shall be kept as close as possible to the torso. Where possible, the tip of fingers should be in x-direction in line with the screws of the knee joint.</p>
Legs	<p>Position the femurs straight forward with a distance of 130mm ± 5mm between the centres of the knees. If the CRS prevents this gap from being achieved, position the knees as close to the target values as possible.</p> <p>Where possible, allow the lower legs to rest naturally. The tibias shall be parallel to the vehicle centreline and the feet shall be separated by the same distance as the knees.</p>
Seatbelt	<p>Follow the CRS installation instructions when routing the seat belt and ensure that the belt is routed correctly through any necessary belt guides.</p> <p>Remove the slack of the lap belt by pulling on the diagonal belt near the buckle with a force of 150N. Ensure that the belt is not twisted in the guidance of the booster cushion.</p> <p>The belt shall initially be positioned over the IR-TRACC (upper for Q10) if possible, a load of 50N shall be applied to the diagonal section of the belt in towards the D-loop to achieve a natural and flat position across the chest. The belt may have moved away from the initial position, there is no need for further adjustment.</p> <p>The use of any non-permanent belt guides or clips on either the vehicle or CRS is prohibited.</p> <p>There must be no tape or stickers applied to the diagonal section of the adult belt.</p>

Once the Q10 dummy has been correctly positioned, the two IR-TRACC holes shall be clearly marked on the suit of the dummy. See Section 2.6 for details on establishing if the vehicle qualifies as limited rear space.

2.5.2 Q10 dummy positioning measurements

The following measurements are to be carried out prior to test but after positioning procedures have been carried out.

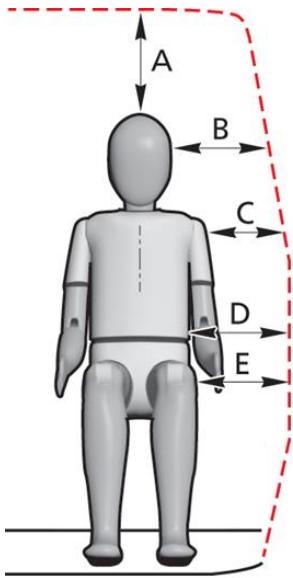

Q10	
A	Top of head to roof (vertically)
B	Head CoG to door/window (horizontal)
C	Shoulder (pivot point) to door/window (horizontal)
D	Lower rib to door (horizontal)
E	Hip joint (femur mounting hole) to door (horizontal)
α	Head angle (where fitted)
β	Pelvic angle (tilt sensor)

2.5.3 Q6 dummy installation

CRS/Dummy	Required setting
CRS	Follow the procedure for Q10 detailed above.
Q6 placement	Follow the procedure for Q10 detailed above. Where the rear head restraints interfere with the CRS, they should be repositioned as necessary to avoid this. They may only be removed if instructed to do so in the vehicle handbook.
Torso	Ensure that the dummy's upper back is in contact with the vehicle seat back if seated on a booster cushion or the back of the CRS if seated in a booster seat. This is done by bending the dummy's back into an upright position and then rocking the dummy sideways while at the same time pushing the pelvis backwards. Ensure that the CRS is aligned with the new reference marks and that the dummy is on the centreline of the CRS and not rotated about the vertical axis. Push the dummy's shoulders toward the seat back or CRS until either the shoulders contact the seat back or the booster seat back. Ensure that the dummy is sitting in an upright position and is aligned with the centreline marks on the head restraint (if applicable) or is parallel to the marks of the centreline. Ensure that the CRS position did not change relative to the marked position.
Arms	The upper arm shall be positioned parallel to the chest. The measurements shall be taken on the neoprene suit along the front surface of the arm (bicep) and along the IR-TRACC on the chest.

CRS/Dummy	Required setting
	Position the lower arms parallel to the upper legs resting on the booster or armrest as close as possible to the side of the femur. The elbows shall be kept as close as possible to the torso.
Legs	<p>Position the femurs straight forward with a distance of 150mm \pm5mm between the centres of the knees. If the CRS prevents this gap from being achieved, position the knees as close to the target values as possible.</p> <p>Where possible, allow the lower legs to rest naturally. The tibias shall be parallel to the vehicle centreline and the feet shall be separated by the same distance as the knees.</p>
Seatbelt	<p>Ensure that the lap belt is routed through the belt guidance of the booster seat.</p> <p>Remove the slack of the lap belt by pulling on the diagonal belt near the buckle with a force of 150N.</p> <p>Route the diagonal belt through the belt guidance of the booster for boosters with high back. Ensure that the belt is not twisted in the guidance of the booster.</p> <p>The belt shall lie naturally across the chest and be allowed to sit as it falls. A load of 50N shall be applied to the diagonal section of the belt towards the D-loop to achieve a natural and flat belt position across the chest.</p> <p>The use of any non-permanent belt guides or clips on either the vehicle or CRS is prohibited.</p> <p>There shall be no tape or stickers applied to the diagonal section of the adult belt.</p>

No dummy positioning measurements are taken for the Q6.

2.6 Determining limited rear space

In advance of test preparation, the OEM shall inform Euro NCAP and the test laboratory if they anticipate the vehicle qualifying for limited rear space assessment. See TB 018.

Reposition the front seat track 30mm forward of its test position. If there is no notch at this position, set the seat in the nearest notch forwards of 30mm. During repositioning, check for interaction between the Q dummy lower legs, feet and the front seat.

With the front seats 30mm forward, if there is no contact between the front of the dummy toes and the seat in front, it is acceptable for the top of the foot/toes to contact the underside of the front seat, reposition the front seats in their test positions. The interaction between the Q dummy lower legs, feet and the front seat is acceptable. Record the pelvic angle.

If there is contact between the dummy and the front seats when they are 30mm forward of their test position, follow the steps below to limit contact between dummy and front seat. This is not relevant if there is only contact between the top of the foot/toes and the underside of the front seat.

Try to reposition the feet and tibias by pushing them beneath the front seat or rotating the tibias about the Z axis. If this is not sufficient then move the pelvis of the dummy forwards while keeping the CRS in place until there is no contact with the seat in front. It is permitted to change the pelvic angle up to 5 degrees relative to the initial pelvic angle. This should be done in incremental steps

until the contact between the toes and front seat is removed. It is acceptable for the top of the foot/toes to contact the underside of the front seat. Record the final pelvic angle.

When the dummy toes remain in contact with the front seat after repositioning the dummy as mentioned above, the vehicle will be treated as limited rear space for that particular test. It is acceptable for the top of the foot to contact the underside of the front seat.

The front seat must be returned to the test position.

3 TEST PROCEDURE

3.1 Summary

Loadcase	Occupant	Head & neck	Chest & abdomen	Knee, femur & pelvis	Lower leg, foot & ankle	Total points
MPDB	Driver	1.25	1.25	1.25	1.25	5.0
	Front passenger	1.25	1.25	1.25	1.25	5.0
	Rear passengers	Head 2.5 Neck 1.25	1.25	-	-	5.0
FWDB	Driver	1.25	1.25	1.25	1.25	5.0
	Front passenger	0.625	0.625	0.625	0.625	2.5
	Rear passenger	0.625	1.25	0.625	-	2.5
Sled	Driver	0.625 / 2	0.625 / 2	0.625 / 2	0.625 / 2	2.5
	Front passenger	0.625 / 2	0.625 / 2	0.625 / 2	0.625 / 2	2.5
Virtual	Driver	0.625 / 3	0.625 / 3	0.625 / 3	0.625 / 3	2.5
	Front passenger	0.625 / 3	0.625 / 3	0.625 / 3	0.625 / 3	2.5

3.2 Colour band scheme

Body region	Criterion	Green	Yellow	Orange	Brown	Red
	Limit value points	< HPL 100%	80%	40%	20%	> LPL 0%
Head & Neck	HIC ₁₅	-				
	A _{res-3ms}	g				
	F _{X, shear}	kN				
	F _{Z, tension}	kN				
	M _{Yxtension}	Nm				
Chest & Abdomen	D _{chest compression}	mm				
	V _{viscous criterion}	m/s				
	D _{abdomen compression}	mm				
	F _{acetabulum}	kN				
	F _{femur}	kN				
	D _{knee}	mm				
Lower Leg, Foot & Ankle	I _{tibia}	-				
	F _{tibia}	kN				

3.2.1 Prediction by OEM

The vehicle manufacturer may provide the Euro NCAP Secretariat with data detailing the protection offered by the vehicle based on CAE or in-house test data, which may then be used in the vehicle rating. This data must be provided to the Euro NCAP Secretariat before any test preparation begins. In order for ANY predicted data to be used in the rating, all of the following requirements must be met:

Data is provided for ALL full-scale tests – MPDB, FWT, AE-MDB, Pole.

Data is provided for all applicable dummy assessment criteria detailed in Section 3.3.

Data is provided based on dummy performance without modifiers applied.

The predicted level of protection offered by the vehicle is verified by Euro NCAP with the use of the full-scale tests. The difference between the predicted data and that recorded in the official test must be within [25%] of the colour band width for each assessment criterion (LPL-HPL)/3.

Example: Hybrid III 5th female, MPDB:

The predicted level of protection offered by the vehicle is verified by Euro NCAP with the use of the full-scale tests.

Body region	Criterion	Green	Yellow	Orange	Brown	Red
Chest & Abdomen	D _{chest} compression	mm < 18	18.0 – 23.33	23.33 – 28.67	28.67 – 33.99	≥ 34.0
			OEM prediction	Test result = 24.5mm		
	Subsequent rating		With OEM prediction	Without OEM prediction		

When a measured dummy parameter performs better than predicted, but within the tolerance, the predicted result is used in the rating. When a measured dummy parameter performs worse than predicted and is outside the tolerance, the measured value shall be used in the rating. After the results comparison has been made, any modifiers identified will then be applied to the relevant body regions and test scores.

Where the OEM provides no predicted data or the data provided does not meet the requirements detailed above in this section, the vehicle rating shall be based on the measured results obtained in the official tests for ALL areas of the assessment.

3.3 Injury criteria and limits

3.3.1 Head & neck

Criterion	HIII 5 th female	HIII 50 th male	THOR 50 th male	HIII 95 th male
-----------	-----------------------------	----------------------------	----------------------------	----------------------------

		HPL - LPL	Capping	HPL - LPL	Capping	HPL - LPL	Capping	HPL - LPL
HIC ₁₅	-	500 - 700	700	500 - 700	700	500 - 700	700	500 - 700
A _{res-3ms}	g	72 - 80	80	72 - 80	80	72 - 80	80	72 - 80
F _{X, shear}	kN	1.2 - 2.0	2.7 Driver only	1.9 - 3.1	3.10	1.9 - 3.1	3.1	2.3 - 3.8
F _{Z, tension}	kN	1.70 - 2.6	2.9 Driver only	2.7 - 3.3	3.30	2.7 - 3.3	3.3	3.3 - 4.0
M _{Y extension}	Nm	36 - 49	57 Driver only	42 - 57	57	42 - 57	57	56 - 76

3.3.2 Chest & abdomen

Criterion	Severity	HIII 5th female		HIII 50th male		THOR 50th male		HIII 95th male
		HPL - LPL	Capping	HPL - LPL	Capping	HPL - LPL	Capping	HPL - LPL
D _{chest compression}	35km/h	18 - 34 ³	34	18 - 34 ³	34	29 - 54 ³	54	-
	50km/h	18 - 34 ³	34	22 - 42 ¹	42	35 - 60 ¹	60	28 - 55 ²
	56km/h	22 - 42 ¹	42	-	-	-	-	28 - 55 ²
V _{viscous criterion}	m/s	0.5 - 1.0	1.0	0.5 - 1.0	1.0	-	-	0.5 - 1.0
D _{abdomen compression}	mm	-	-	-	-	88	-	-

45 year old¹, 50 year old², 65 year old³

3.3.3 Knee, femur & pelvis

Criterion		HIII-05	HIII-50	THOR-50	HIII-95
F _{acetabulum}	kN	-	-	3.3-4.1	-
F _{femur}	kN	2.6-6.2	3.8-9.1	3.8-9.1	4.8-11.5
D _{knee}	mm	6-15	6-15	6-15	6-17

3.3.4 Lower leg, foot & ankle

Criterion		HIII-05	HIII-50	THOR-50	HIII-95
I _{tibia}	-	1.3	0.4-1.3	0.4-1.3	0.4-1.3
F _{tibia}	kN	8.0	2.0-8.0	2.0-8.0	4.0-10.0

3.3.5 Child occupants

Body region	Criteria		Q6	Q10	Capping
Head	HIC ₁₅	-	500 - 700	500 - 700	700
	A _{res-3ms}	g	60 - 80	80	80
Neck	F _{Z,tension}	kN	1.7 - 2.62	2.62	-
	M _{Yxtension}	Nm	36	49	-
Chest	D _{chest compression res}	mm	30 - 42	[28] - 56	56
	A _{res-3ms}	g	-	41 - 55	55

Chest acceleration peaks caused by the firing of seatbelt pretensioners early in the loading event will be ignored.

3.4 MPDB

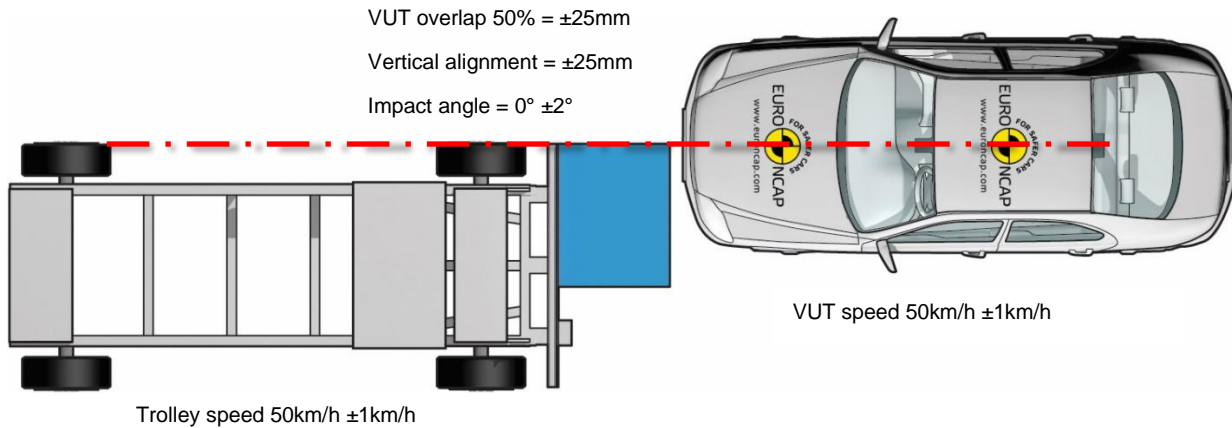

Figure 2 MPDB test alignment - Drawing to be updated

The laboratory shall include on the vehicle or MPDB face a physical means of identifying the overlap between the MPDB face and vehicle at T0.

A method may be employed to prevent secondary impacts between the vehicle and trolley. This may be an emergency braking system on the vehicle and trolley or another method. There must be no braking at T0. Braking must NOT begin until 100ms after the vehicle velocity has reached zero or 100ms after T0 where the vehicle continues to move forward. The OEM will be asked to supply an OLC curve for the vehicle.

Measure the speed of both the test vehicle and the trolley as near as possible to the point of impact. Record the actual test speeds in the test report.

If the impact alignment cannot be established, film analysis will be used to try to assess the alignment. Both the horizontal and vertical alignments shall be noted in the test report along with the impact angle of both the test vehicle and the trolley as near as possible to the point of impact.

3.5 FWT

The sagittal plane of the vehicle and barrier face shall be coincident.

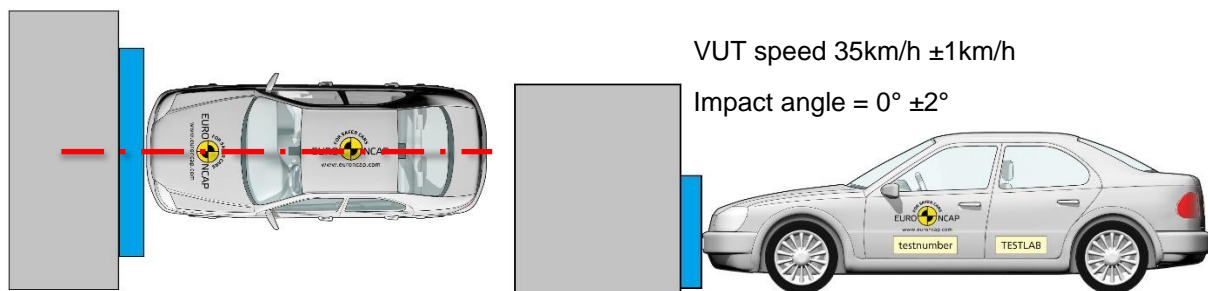

Figure 3 FWT test set-up

Measure the speed of the vehicle as near as possible to the point of impact.

3.6 Virtual testing and sled

The vehicle manufacturer shall provide Human Body Model (HBM) simulation data to be eligible for the full points for the virtual loadcases. When this data is not provided, the Virtual score is halved.

3.6.1 Loadcase matrix

	Sled & Virtual		Virtual			
	50 km/h	56 km/h	35 km/h	35 km/h	56 km/h	50 km/h
Severity	50 km/h	56 km/h	35 km/h	35 km/h	56 km/h	50 km/h
Pulse	R137	Vehicle*	FWDB	FWDB	Vehicle*	R137
Driver	H-III 50 th	H-III 95 th	H-III 50 th	H-III 5 th	H-III 5 th	HBM 50 th
Front Passenger	H-III 95 th	H-III 5 th	H-III 5 th	H-III 50 th	H-III 95 th	-

* Vehicle means a vehicle specific pulse from a physical or virtual test at 56km/h provided by the OEM meeting the requirements of TB 056.

High severity generic pulse – 56km/h
Where this 56km/h data is not available, a generic high severity pulse must be used as defined by Euro NCAP. The generic pulse is a fallback case only and its use in this procedure will be reconsidered by Euro NCAP in the future.
The generic pulse is intended to be ‘worst case’ and must be more severe than that observed by Euro NCAP in the 50km/h MPDB test. Where this is not the case, all high severity VTC data will receive no reward.
Two generic pulses are available and are applicable to only vehicle of the power sources identified: <div style="margin-left: 40px;">Pulse 1 – For PHEV and ICE powered vehicles only</div> <div style="margin-left: 40px;">Pulse 2 – For Battery electric vehicles only</div>
The generic pulse is a fallback option only and its use in this procedure will be reconsidered by Euro NCAP in the future.
The pulses are available from the Euro NCAP website.

4 POST-TEST ASSESSMENT & INSPECTION

4.1 After test

Immediately after the test, check that none of the doors and boot lids, have opened or partially opened during the test. Where this is the case photographic evidence shall be obtained and provided in the test report.

Refer to the Post Crash protocol for further details of all post-test assessments and provide all required information in a Post crash report.

4.1.1 Dummy removal

Before dummy removal, refer to the Post Crash protocol for seat belt buckle unlatching.

Before dummy removal measure the distance between all foot pedals and a fixed point in the footwell, e.g. seat runner, seat mounting bolt. If access cannot be gained remove the dummies taking care not to disturb any pedals and then record the measurement. This measurement should be re-checked before the pedals are measured with the 3D measuring system. If the pedal has moved re-position the pedal using the measurement taken previously.

Do not move the driver or passenger seats, try to remove the dummies. If the dummies cannot be removed with the seats in their original positions, recline the seat back and try again. Note any entrapment of the dummies. If the dummies can still not be removed, try to slide the seats rewards on their runners. If the dummies can still not be moved, the seats may be cut out of the car.

Record the method used to remove the dummies.

4.2 Intrusion measurements

Take the post test vehicle intrusion measurements defined in Technical Bulletin TB 046.

4.3 Barrier face measurement

If the vehicle and barrier face are still connected, care must be taken to separate the two with minimal deformation of the honeycomb. If the two cannot be separated without deforming the honeycomb, remove the barrier from the trolley and try to manoeuvre the barrier face to make separation easier. If this is not successful, vehicle structures should be removed, such as the longitudinals and bumper cross beam. It may be necessary to remove the front wheels and side wing to gain better access to the vehicle structures.

Clean the surface of the barrier from fluids, rough dirt, glass, plastic pieces, loose tape, etc.

Eliminate mechanical artefacts:

In some cases it might be that deformation has occurred that was not caused by the impact but would influence the results in an undesired way. These artefacts should be corrected and documented before the final scan of the barrier surface.

In case of different honeycomb layers separating at the adhesive joints, try to bring them back in contact without further deformation of the honeycomb structure (e.g. with the help of a ratchet strap). To make this easier, remove the cover sheet metal from top and bottom of the barrier.



It may be that the cover sheet metal is bent outward due to car parts getting hooked during rebound (this usually happens at borders of holes punched in by longitudinal beams). In this case, reform the cover sheet metal to match to the contour of the honeycomb.

Sometimes parts of the longitudinal beams may get stuck in the barrier. In this case the barrier scan may be split up in two or more segments. First scan the barrier surface as far as possible without needing to remove the part of the car. Then carefully remove the part with as little influence on the original barrier surface as possible. After that scan the bottom of the hole that is now accessible.

Cracks that are obviously not caused by intrusion shall be filled with clay before scanning (from edge to edge of the cover sheet metal).



Where necessary paint any areas of bare metal on the surface (e.g. with bright priming coat) to enhance scanning quality in these areas.

Align the barrier to the measurement system with the help of the eight reference points (left and right side of the flange plate) measured before crash. If the honeycomb has separated from the backplate, the reference points on the unstruck side of the rear honeycomb layer shall be used.

Scan the barrier surface to get a point cloud of the deformed surface. An area of the size of the undeformed barrier surface (projected to the deformed barrier surface in X direction) is sufficient.

Create a mesh from this point cloud. As parameter a maximum edge length of 10mm shall be used. If available, medium smoothing and data reduction can be applied.

Create a grid of points with an equal distance of 20mm centred on the undeformed barrier surface. This will be a number of 1400 points in total.

Grid1 X=0 Y=10 Z=10	Grid2 X=0 Y=30 Z=10	Grid50 X=0 Y=990 Z=10
Grid51 X=0 Y=10 Z=30	Grid52 X=0 Y=30 Z=30	Grid100 X=0 Y=990 Z=30
.....
.....
Grid1351 X=0 Y=10 Z=550	Grid1352 X=0 Y=30 Z=550.....	Grid1400 X=0 Y=990 Z=550

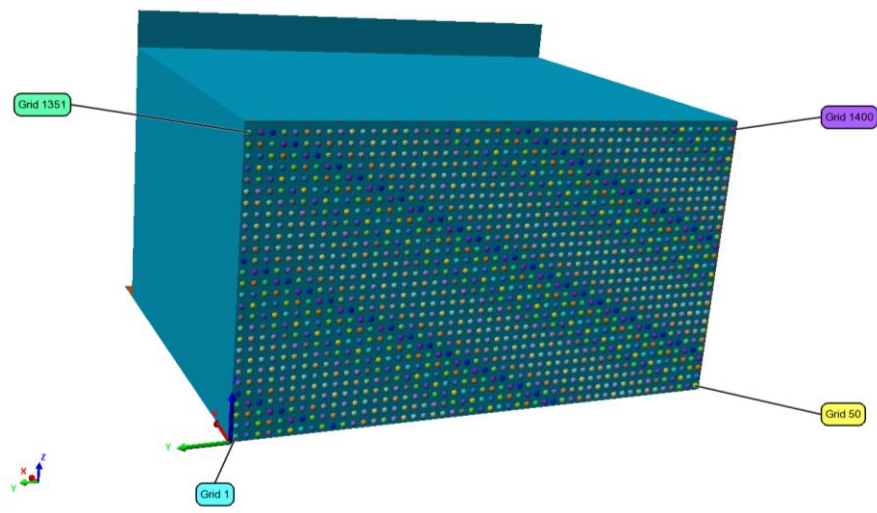

The grid points shall be projected on the mesh of the scanned barrier surface along the X axis.

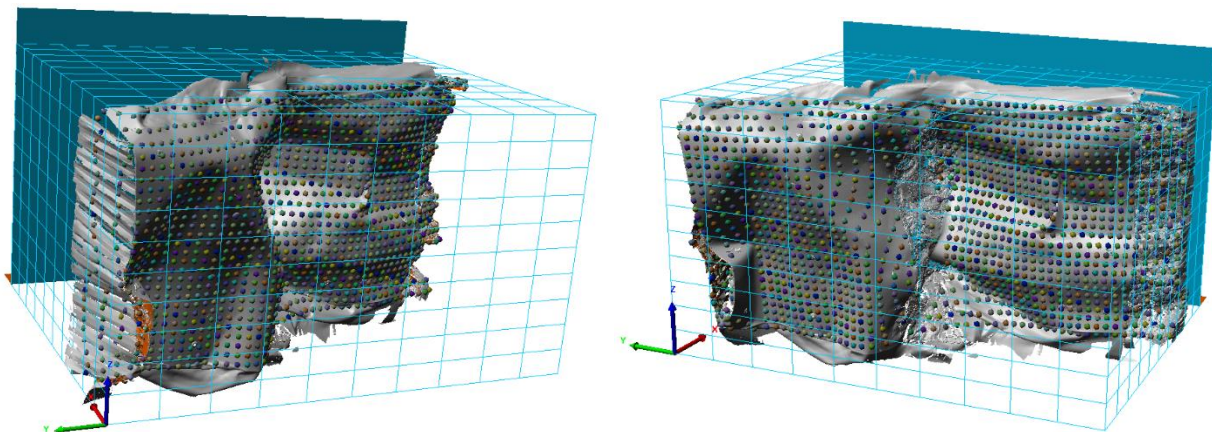

It may be that some points do not hit the mesh (e.g. because of holes in the mesh). This can be ignored if the points are not in the assessment area. Points in the assessment area should be placed as close as possible to the desired position by considering the X value of the neighbouring grid points or the surrounding mesh surface.

Finally, the co-ordinates of the grid points shall be exported to the assessment file.

4.4 Inspection

After the test, Euro NCAP will perform a vehicle inspection where scoring modifiers can be applied. The inspection manual describes the inspection procedure and the criteria applied.

4.4.1 MPDB and FWT modifiers

Front Occupant	Modifiers	Criterion	Modifier score
Head & neck	Head bottoming out	Inspection	-0.25
	Unstable airbag contact	Inspection	-0.25
	Hazardous airbag deployment	Inspection	0.25
	DAMAGE (THOR-50)	$0.42 \leq \text{DAMAGE} < 0.47$ ≥ 0.47	-0.25 -0.5
	Incorrect airbag deployment	Inspection	-0.25
Chest	Steering wheel contact	Inspection	-0.25
	Shoulder belt load	5 th & 50 th Percentile \geq 6.00kN	-0.5
	Steering column displacement	Rearward 90mm–110mm Vertical 72mm-88mm	-0.25
	Incorrect airbag deployment	Inspection	-0.25
Knee, femur and pelvis	Submarining	Inspection	-1.25
	Knee load – Variable	$\geq 3.8\text{kN}$ or 6.0mm Inspection	-0.25
	Knee load – Concentrated	Inspection	-0.25
	Incorrect airbag deployment	Inspection	-0.25
Lower leg, foot and ankle	Pedal displacement	Rearward 100mm-200mm Vertical 72mm-88mm	-0.25
	Pedal blocking	50mm-175mm	-0.25

Rear occupants	Modifiers	Criterion	Modifier score
Head & Neck	Head bottoming out	Inspection	-0.25
	Unstable airbag contact	Inspection	-0.25
	Hazardous airbag deployment	Inspection	0.25
	Incorrect airbag deployment	Inspection	-0.25
	Excursion	≥ 450mm ≥ 550mm	-0.625 -1.25
Head	Q6 excursion	550mm	-2.5
	Q10 excursion	≥ 450mm ≥ 550mm	-1.25 -2.5
Chest	Shoulder belt load	≥ 6.00kN	-0.5
	Incorrect airbag deployment	Inspection	-0.25
Knee, femur and pelvis	Submarining	Inspection	-1.25
	Incorrect airbag deployment	Inspection	-0.25
Lower leg, foot and ankle	-	-	-

Test penalties	Modifiers	Criteria	Modifier score
A-pillar	Rearward displacement	100mm-200mm	-0.25
Bodyshell integrity		Inspection	-0.25
Footwell rupture		Inspection	-0.25
Compatibility TB 027	OLC	25g-40g	
	Standard deviation	50mm-150mm	-5
	Bottoming out	Inspection	
Q dummy restraint	Belt off shoulder	Inspection	-5
	Belt slippage	Inspection	-2.5
Q dummy	Submarining	Inspection	-5
Q dummy	Ejection	Inspection	-5
CRS attachment		Inspection	-5
Restraint failure	Non-deployment	Inspection	-10
Door opening	Per door	Inspection	-0.5
Door detachment	Structural detachment	Inspection	-10

4.4.2 Sled and VTC modifiers

Front Occupant	Modifiers	Criterion	Modifier score
Head & neck	Head bottoming out	Inspection	[0.625 / 3]
	Unstable airbag contact	Inspection	[0.625 / 3]
	Hazardous airbag deployment	Inspection	[0.625 / 3]
	Incorrect airbag deployment	Inspection	[0.625 / 3]
Chest	Steering wheel contact	Inspection	[0.625 / 3]
	Shoulder belt load	5 th & 50 th Percentile \geq 6.00kN	[0.625 / 3]
	Incorrect airbag deployment	Inspection	[0.625 / 3]
Knee, femur and pelvis	Submarining	Inspection	[0.625 / 3]
	Knee load – Variable	\geq 3.8kN or 6.0mm Inspection	[0.625 / 3]
	Knee load – Concentrated	Inspection	[0.625 / 3]
	Incorrect airbag deployment	Inspection	[0.625 / 3]

4.5 Scoring and visualisation

The scores for each occupant and body region are calculated individually.

The protection provided for adults for each body region are presented visually, using coloured segments within body outlines. The colour used is based on the points awarded for that body region and rounded to three decimal places, as follows:

Colour	Performance	Criterion score
Green	Good	100%
Yellow	Adequate	$66.67\% \leq \text{score} < 100\%$
Orange	Marginal	$33.33\% \leq \text{score} < 66.67\%$
Brown	Weak	$0\% < \text{score} < 33.33\%$
Red	Poor	0%